



Portable - Pico Event Timer Upgrade

Karel Hamal , Ivan Prochazka

*presented at
the 13th Workshop on Laser Ranging
Washington DC, October 7-11, 2002*

Czech Technical University, Prague, Czech Republic

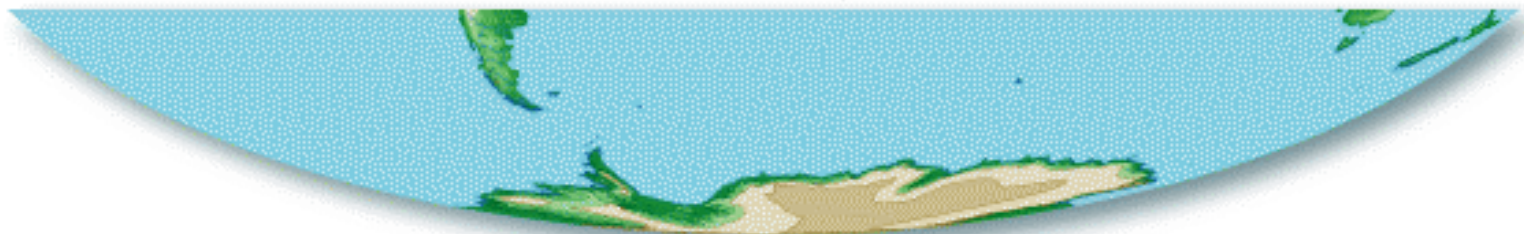

Portable Pico Event Timer Upgrade

Goals

- timing resolution increase to 2.5 psec/channel
 - new Dassault ETM modules
- measurement repetition rate increase
 - higher communication speeds
- increased timing stability
 - new input circuits
- timing linearity self-test built in
 - new HW and SW package
- capability to co-operate with multi kHz systems
 - advanced input arming logic

Portable Pico Event Timer Upgrade SLR INTEGRATION

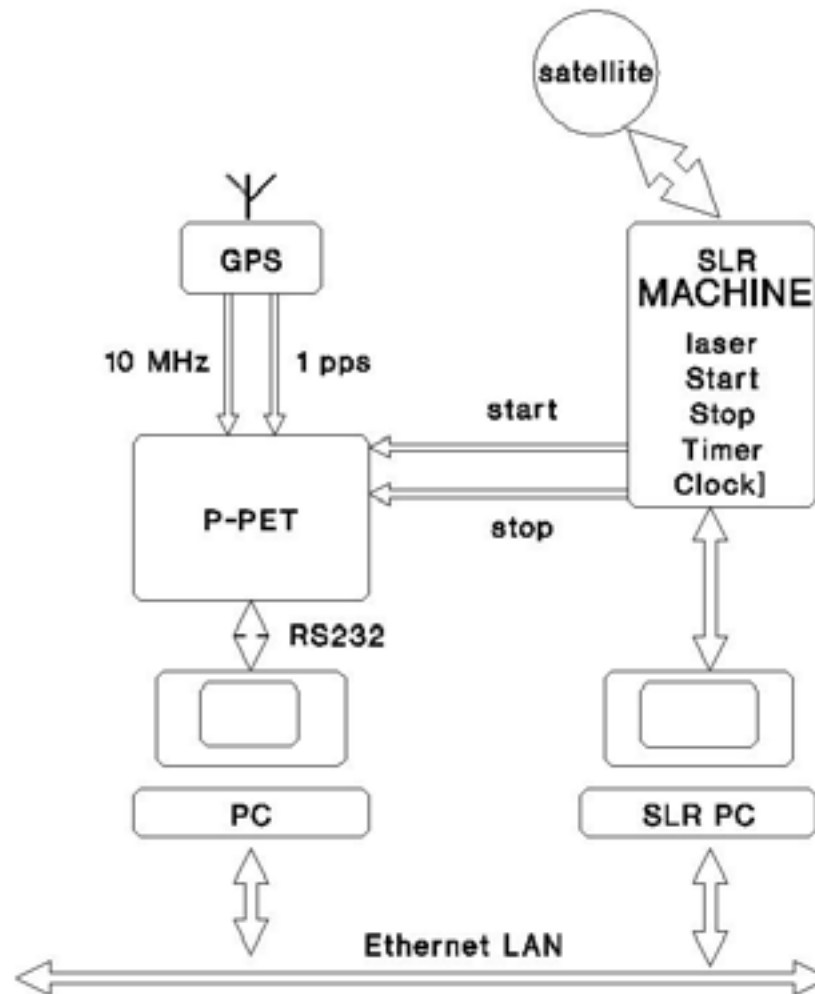

K.Hamal,I.Prochazka, EurOpto, London 1997

K. Hamal, I. Prochazka, Prague,
September 2002

Portable Pico Event Timer Upgrade SLR SOFTWARE INTEGRATION

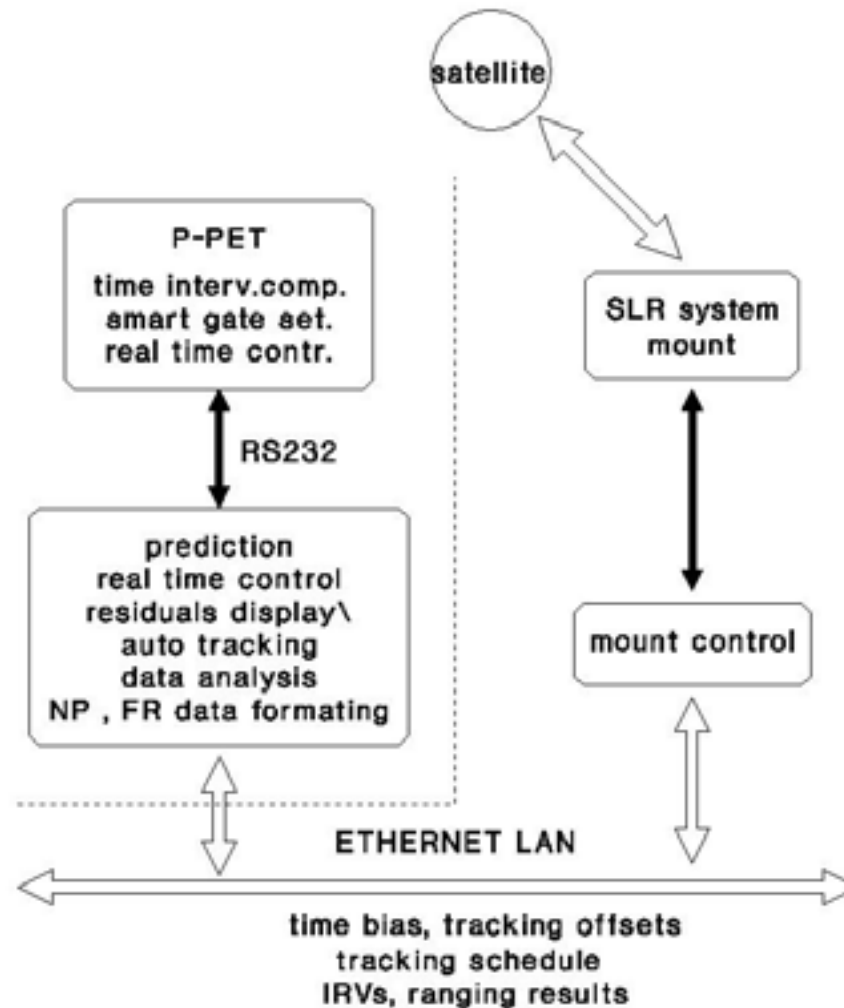

K.Hamal,I.Prochazka, EurOpto, London 1997

K. Hamal, I. Prochazka, Prague,
September 2002

Portable Pico Event Timer Upgrade



K. Hamal, I. Prochazka, Prague,
September 2002

Portable Pico Event Timer Upgrade

P-PET temperature drift test

Cable delay test,

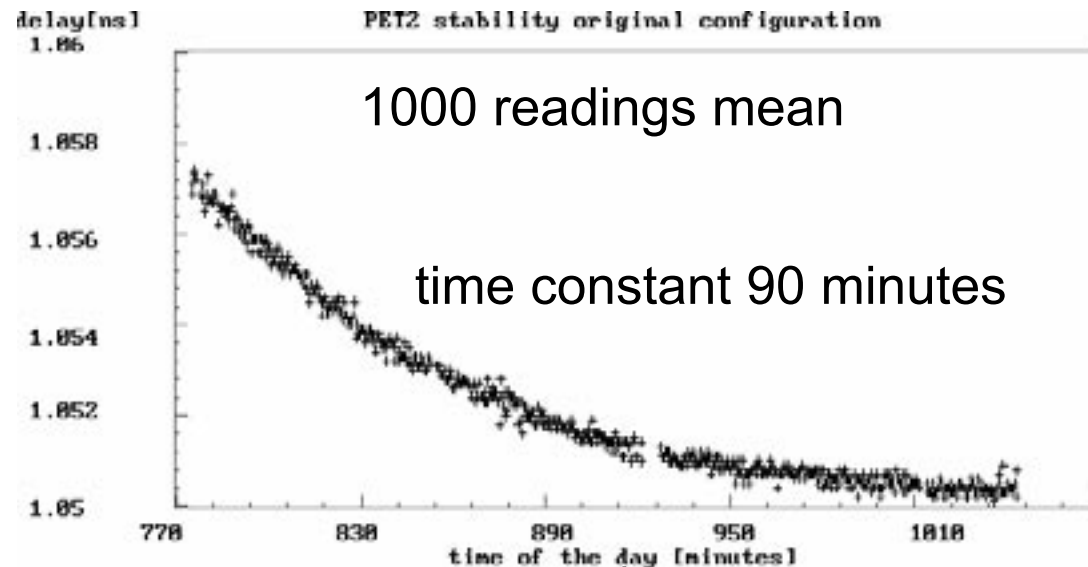

10 ps/screen

+20.8 C

5 hours / screen

+35.9 C

PET2 time drift -0.53 psec / K

K. Hamal, I. Prochazka, Prague,
September 2002

Portable Pico Event Timer Upgrade

P-PET temporal stability test

Cable delay test, 1 hour series
25 +/- 1 deg. C, no airconditioning

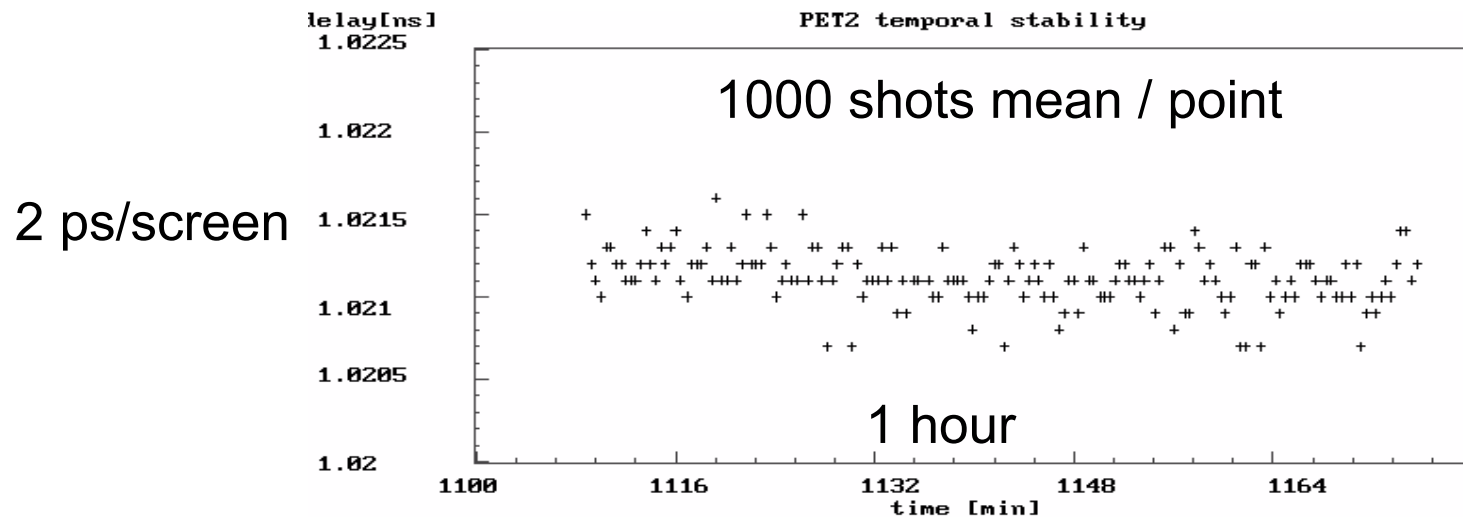

PET2 temporal stability +/- 0.45 ps 1 hour

K. Hamal, I. Prochazka, Prague,
September 2002

Portable Pico Event Timer Upgrade

P-PET timing linearity test

Internal self test

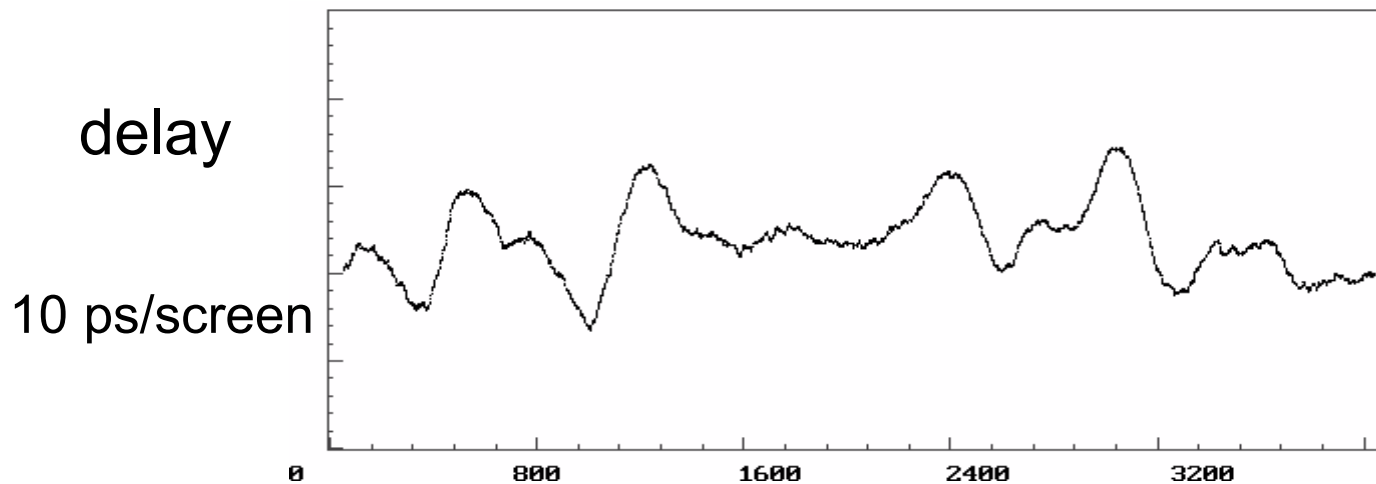

TDC channel No,

Cable delay timing test,

measured time interval Start=>Stop versus Start TDC channel No
moving average, 100/10 k readings

P-PET2 linearity error < +/- 2.8 ps

K. Hamal, I. Prochazka, Prague,
September 2002

Portable Pico Event Timer Upgrade

P-PET Parameters Upgrade

	London 97 =>	Wash 2002
•		
• timing resolution	1.2 ps	
• timing jitter / channel	5 ps	2.5 ps
• non-linearity / channel	< 5 ps (spec)	< 2.5 ps (meas)
• temperature drift	< 0.7 ps/K	< 0.53 ps/K
• temperature time const.		90 minutes
• temporal stability	+/- 1.0 ps/hr	+/- 0.45 ps/hr
• max. repetition rate	30 Hz	100 Hz, 2MHz sampl
• No. of channels	2(4)	
• interface	RS232	
• mass transport	32 kg	

K. Hamal, I. Prochazka, Prague,
September 2002

Ground Ranging Machine Error Budget

Contribution		random		systematic	
		1 pe	100 pe		
Laser	pulse	14 ps	1 ps		
Start	jitter	3 ps	3 ps	walk	2 ps
Stop	jitter	25 ps	5 ps	walk	3 ps
Timing	jitter	3 ps	3 ps	stability	1 ps
				linearity	3 ps
Mount				eccentr.	
Calibration				survey	
Total	rss	30 ps	7 ps	rss	6 ps
Ground calibration			30 ps	7 ps	

Laser 35 ps, C-SPAD, PET