

**SECTION III: RETROREFLECTOR ARRAY INFORMATION:**

A prerequisite for accurate reduction of laser range observations is a complete set of pre-launch parameters that define the characteristics and location of the LRA on the satellite. The set of parameters should include a general description of the array, including references to any ground-tests that may have been carried out, array manufacturer and whether the array type has been used in previous satellite missions. So the following information is requested:

Retroreflector Primary Contact Information:

Name: Yoshimi Ohshima

Organization and Position: Mission Design Department Space Systems Division, NEC Corporation, Assistant Manager

Address: Mail Code :41000 1-10 Nisshin-cho, Fuchu-city, Tokyo, 183-8501, Japan.

Phone No.: +81 42 333 3938

E-mail Address: y-ohshima@cb.jp.nec.com

Array type:

- Single reflector
- Spherical
- Hemispherical/Pyramid
- Planar
- other (specify: \_\_\_\_\_ )

Attach a diagram or photograph of the satellite that shows the position of the LRA, at the end of this document.

Attached

Attach a diagram or photograph of the whole LRA at the end of this document.

- Attached
- Same as above, Not attached (acceptable only for a cannonball satellite)

Array manufacturer:

Honeywell Technology Solutions Inc.

Link (URL and/or reference) to any ground-tests that were carried out on the array:

n/a

Has the LRA design and/or type of cubes been used previously?

- No
- Yes (List the mission(s): QZS-1, ETS-VIII)

For accurate orbital analysis it is essential that full information is available in order that the 3-dimensional position of the satellite center of mass may be referred to the location in space at which the laser range measurements are made. To achieve this, the 3-D location of the LRA phase center must be specified in a satellite-body-fixed reference frame with respect to the satellite's mass center. In practice this means that the following parameters must be available at 1 mm accuracy or better.

Define the satellite-body-fixed XYZ coordinates (i.e. origin and axes) on the spacecraft:  
(specify) (add a diagram in the attachment)

see in the diagram in the attachment.

Relate the satellite-body-fixed XYZ coordinates to a Celestial/Terrestrial/Solar Reference Frame including the attitude control policy:  
(specify) (add a diagram in the attachment)

Z axis points toward Earth.

The 3-D location of the satellite's mass center in satellite-body-fixed XYZ coordinates is:

- Always fixed at (0, 0, 0)
- Always fixed at ( \_\_\_\_\_ , \_\_\_\_\_ , \_\_\_\_\_ ) in mm
- Time-varying by approximately ( 70 ) mm during the mission lifetime.  
Will a time-variable table of the mass center location be available on the web?
  - No
  - Yes (URL: \_\_\_\_\_ )

The 3-D location (or time-variable range) of the phase center of the LRA in the satellite-body-fixed XYZ coordinates:

( -988.2 , -860.8 , 4373.3 ) in mm

The following information on the corner cubes must also be supplied.

The XYZ coordinates referred to in the following are given in:

- Satellite-body-fixed system (same as above)
- LRA-fixed system (specify below)  
(specify the origin and orientation) (add a diagram in the attachment )

List the position (XYZ) of the center of the front face of each corner cube, and the orientation (two angles or normal vector) and the clocking (horizontal rotation) angle of each corner cube. Note that the angles should be clearly defined.

- Attached at the end of this document
- Listed here (acceptable for small number (10 or fewer) of corner cubes)  
(specify) (add a diagram in the attachment)

n/a
-----

Is the corner cube recessed in its container (i.e. can the container obscure a part of the corner cube)?

- No
- Yes (specify below)

(specify) (add a diagram)

--

The size of each corner cube: Diameter (40.6) mm Height (29.7) mm

The material from which the cubes are manufactured (e.g. quartz):

quartz

The refractive index of the cube material

= 1.461 for wavelength  $\lambda = 0.532$  micron

= N/A as a function of wavelength  $\lambda$  (micron):

The group refractive index of the cube material, as a function of wavelength  $\lambda$  (micron):

= 1.461 for wavelength  $\lambda = 0.532$  micron

= N/A as a function of wavelength  $\lambda$  (micron):

Dihedral angle offset(s) and manufacturing tolerance (in arcseconds):

0.8 +/- 0.3

---

Radius of curvature of front surfaces of cubes:

Not applied     Yes (specify: \_\_\_\_\_)

Flatness of cubes' surfaces:

53.2nm

---

Back-face coating:

Uncoated     Coated (specify the material: MgF2 anti-reflective)

**Other comments on LRA:**

(specify) (add a reference to a study of the optical response simulation/measurement if available) (add a diagram if applicable)

n/a

1. Photographs of LRA

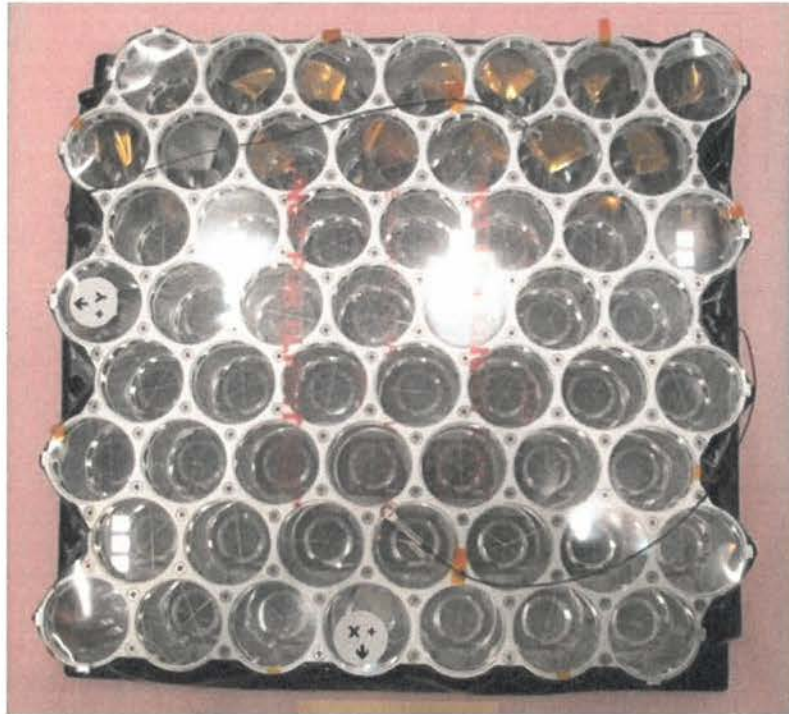

2. Diagram of satellite-body-fixed XYZ coordinates on the spacecraft

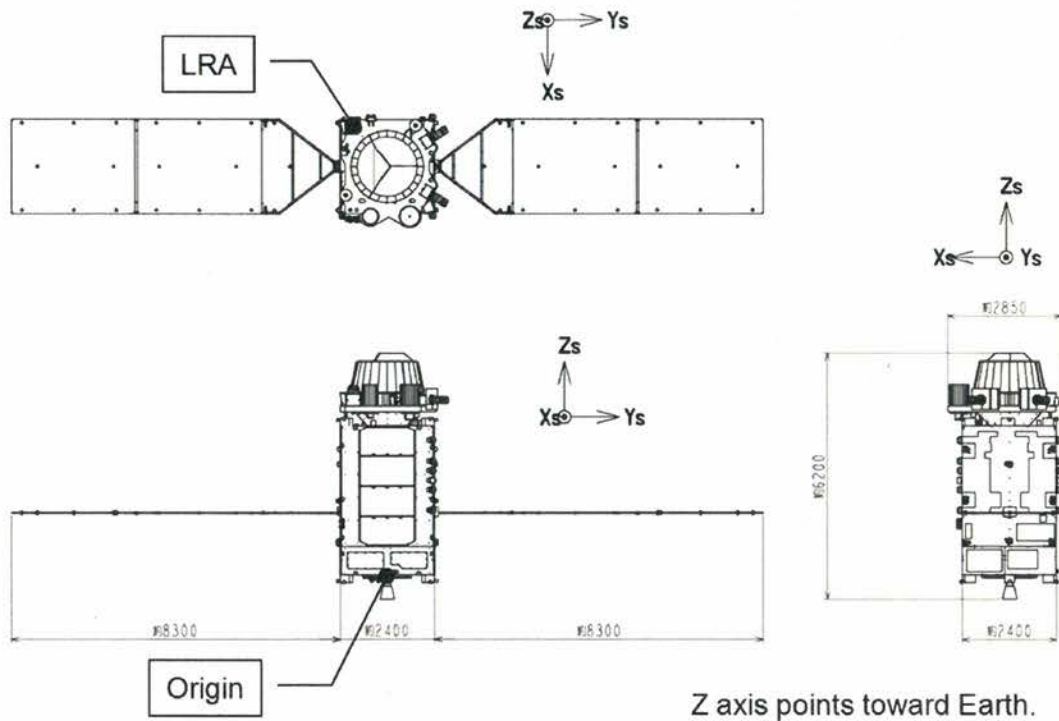

3. Center of Mass Information

3-D location (possibly time-dependent) of the satellite's mass center relative to a satellite-based origin:

At BOL, the satellite's mass center is given by  $(x,y,z)=(0.0, 0.0, 1812.6)$  [mm]

At EOL, the satellite's mass center is given by  $(x,y,z)=(0.0, 0.0, 1882.3)$  [mm]