

## SIMULTANEOUS SPACE DEBRIS LASER RANGING AND LIGHT CURVE MEASUREMENTS OF A LARGE RE-ENTERING UPPER STAGE

SLR Station Graz

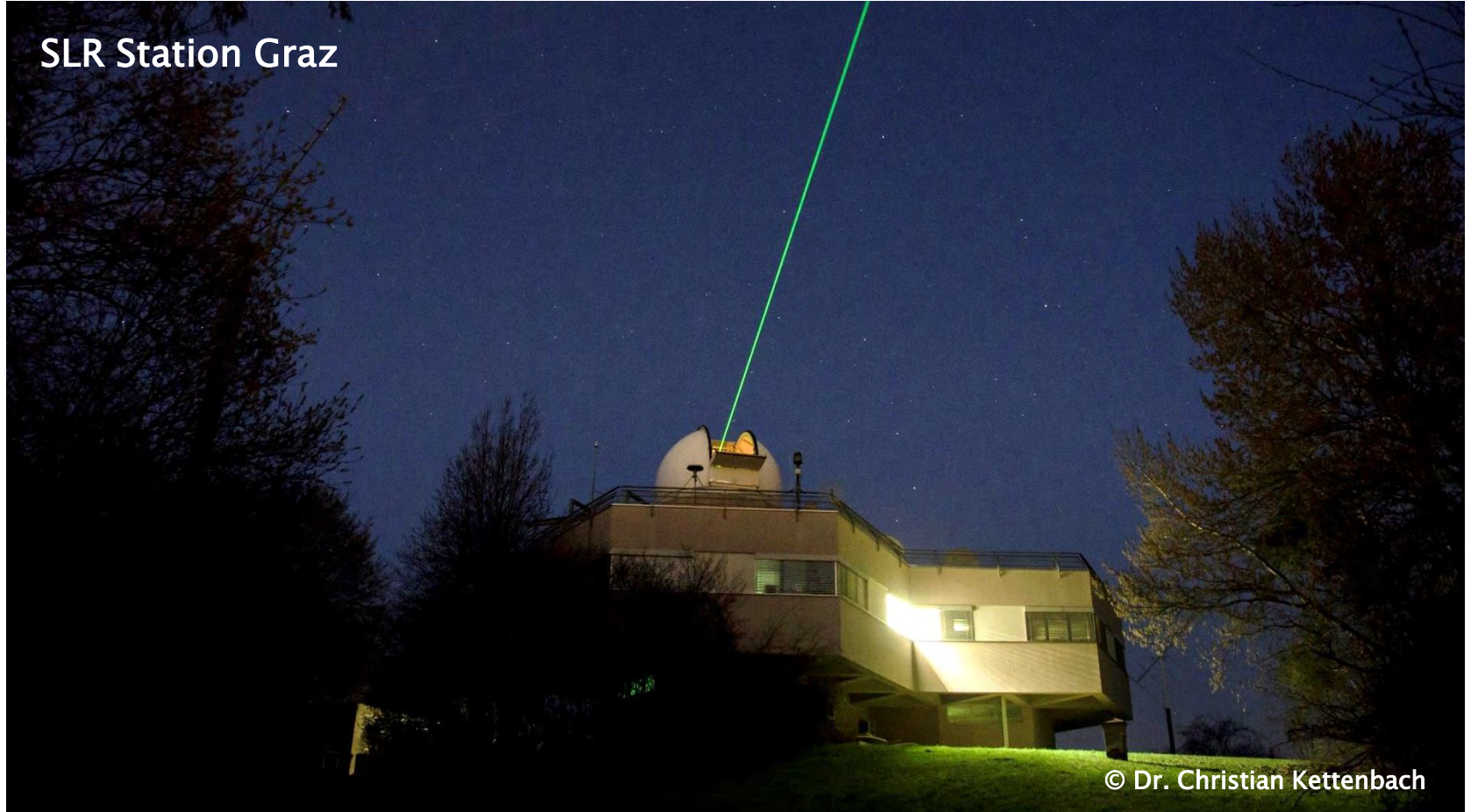

© Dr. Christian Kettenbach

Michael Steindorfer, Georg Kirchner, Franz Koidl, Peiyuan Wang  
Space Research Institute, Austrian Academy of Sciences

# DETAILS: RE-ENTRY OBJECT

- CZ-3B R/B, Norad ID 38253, Third stage of Long March 3B rocket
- Source: <http://www.spaceflight101.net/long-march-3b.html>

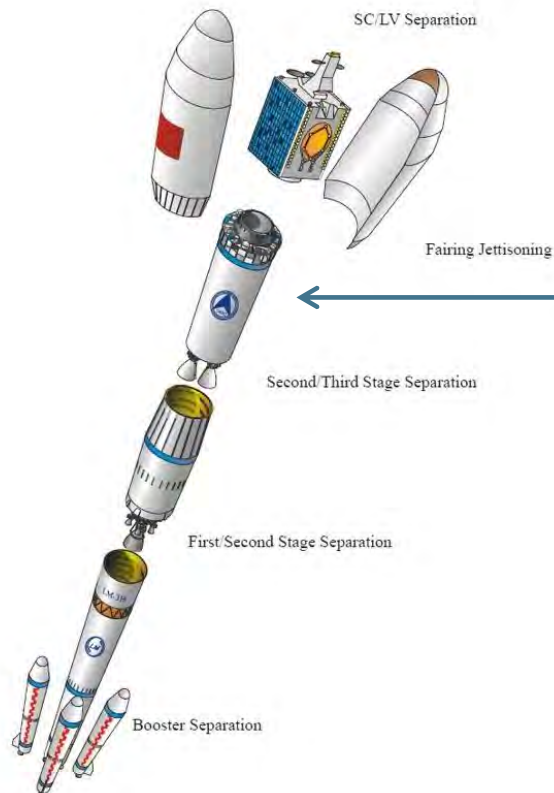

## Third Stage

Type	CZ-3B Third Stage
Length	12.38m
Diameter	3.0m
Launch Mass	20,933kg
Empty Mass	2,740kg
Fuel	Liquid Hydrogen
Oxidizer	Liquid Oxygen
Propellant Mass	18,193kg
Propulsion	YF-75
Thrust	156.9kN
Specific Impulse	4,312Ns/kg
Chamber Pressure	37.6bar
Area Ratio	80
Restart Capability	Yes
Prop Utilization	Yes
Burn Time	469s
Control	Engine Gimbaling (Pitch & Yaw)
Attitude Control Sys	4x70N, 8x40N (Roll, Pitch & Yaw)
Prop Management	2x300N, 2x45N

# ORBITAL PARAMETERS UNTIL RE-ENTRY

2017-07-01 - 2017-08-19 (reentry: 2017-08-18), TLE source: space-track.org

## inclination

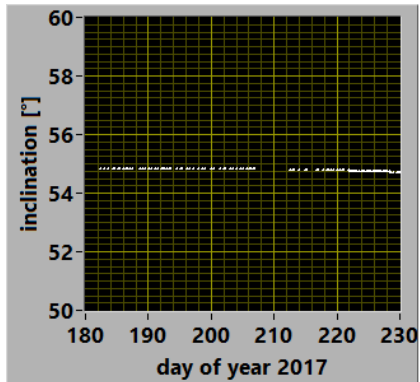

## eccentricity

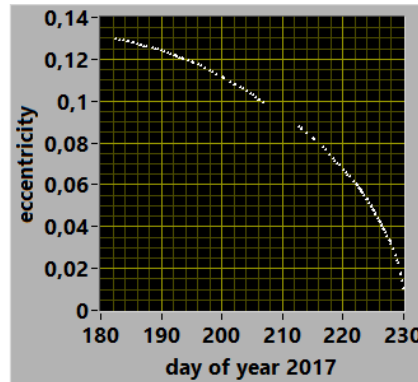

## arg. of perigee

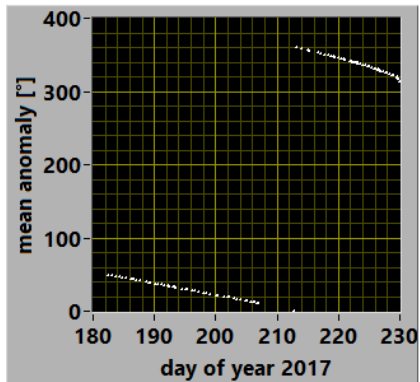
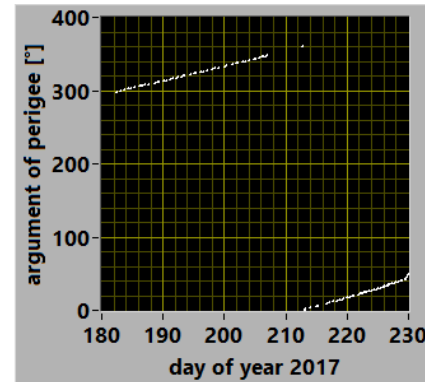

## Mean anom

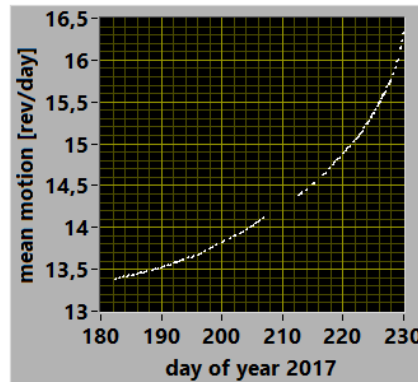

## mean motion

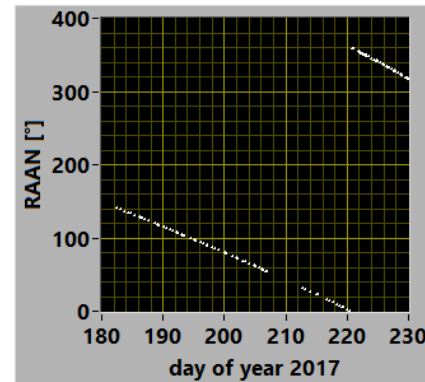

## RAAN

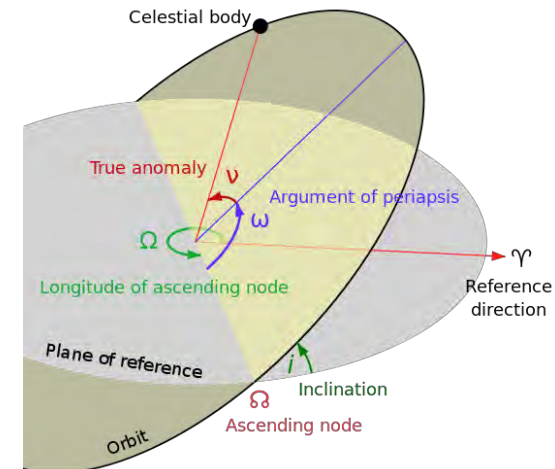

# SLR & LIGHT CURVES

Simultaneous space debris laser ranging and light curve measurements:

- 100 Hz, 3 ns, 20 W, 200 mJ // LC-SPAD wavelength  $\approx$  532 nm used
- x-axis: seconds of day 184 (2017-07-03)
- y-axis: SLR range residuals [m] (green), max. slant ranges  $\sim$ 3000 km
- y-axis: Light curve (white), scaled & shifted to fit in SLR plot range)

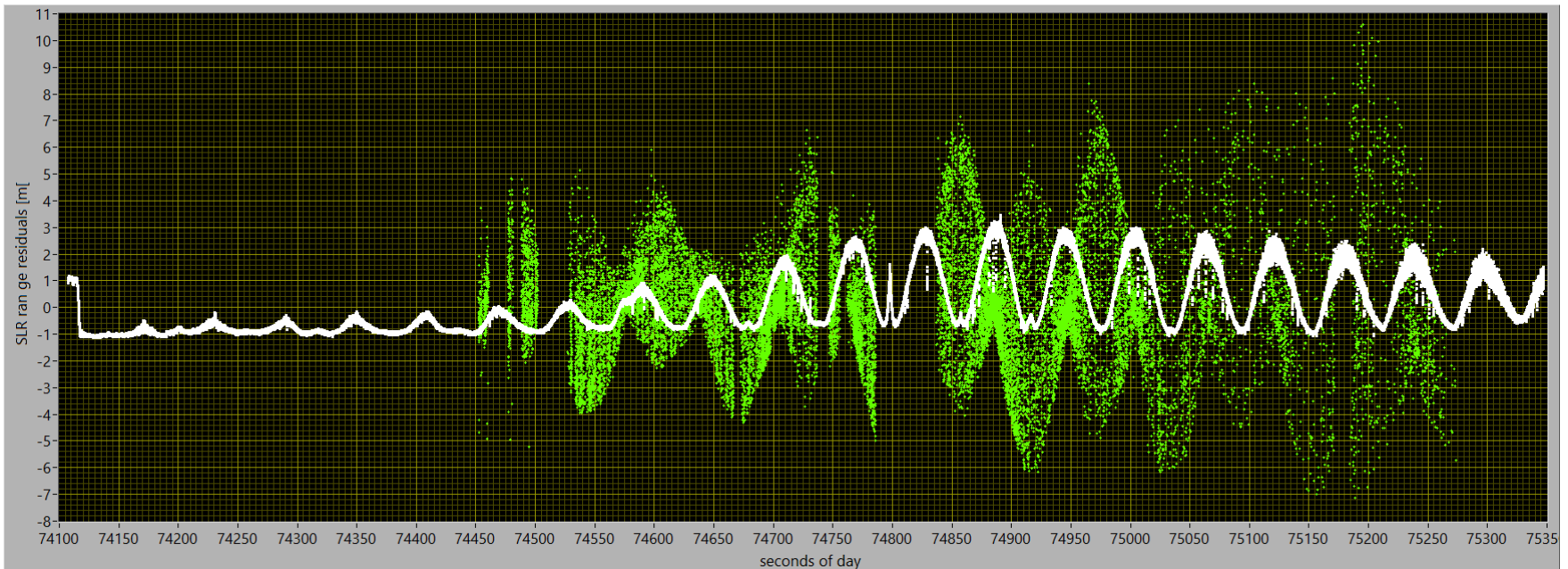

# SPACE DEBRIS LASER RANGING / LIGHT CURVES

- Maximum SLR residuals  $\leftrightarrow$  Small light curve peaks
- Minimum SLR residuals  $\leftrightarrow$  Large light curve peaks
- Maximum SLR offset: approx. 13 meters
  - Cylinder axis roughly parallel to line of sight
  - Sunlight reflection from top/bottom cylinder surface
- Large LC peaks: Sunlight reflection from cylinder jacket (SLR Minimum)
- Small LC peaks: Sunlight reflection from top/bottom surface
- Periodical offset SLR  $\rightarrow$  rotation about center of mass

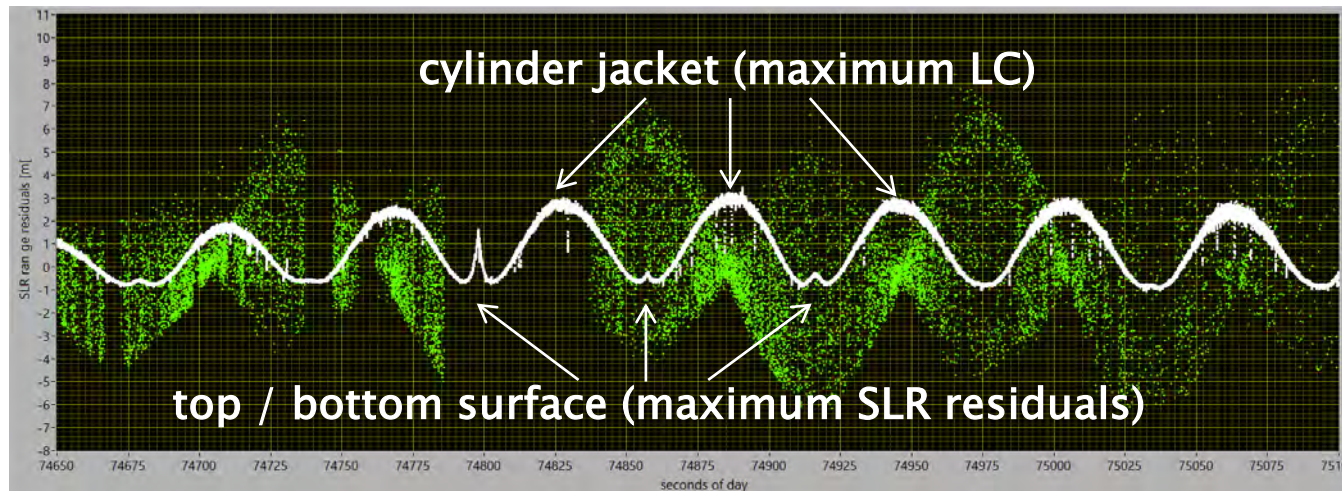

# LIGHT CURVE SIMULATIONS

$$I = \frac{I_{sun} A_{eff}}{4\pi R^2 (earth - object)}$$

$$A_{eff} = \sum_{j=1}^N A_j a_j (\vec{n}_j \vec{l})_+ (\vec{n}_j \vec{o})_+$$

$a_j$  ... surface albedo

$A_j$  ... surface area

$\vec{n}_j$  ... surface normal vector, object

$\vec{l}$  ... vector object - sun

$\vec{o}$  ... vector object - observer

Reference: ANALYSIS OF OBSERVED AND SIMULATED LIGHT CURVES OF SPACE DEBRIS

*Carolin Früh, Thomas Schildknecht, Astronomical Institute, University of Bern, Switzerland*

# SIMULATION DETAILS LIGHT CURVE / SLR

## Light curves

- 1) Define set of cylinder surface normal vectors in ECI system
- 2) Define surfaces parameters according to rocket body dimensions
- 3) Rotate cylinder (normal vectors) to starting position / starting phase
- 4) Propagate & rotate **normal vectors** along SGP4 path
- 5) Enter in formula (sun/satellite position) -> Calculate light curves

## SLR residuals

- 1) Calculate surface vectors: Cylinder center (SGP4) - Cylinder surface
- 2) Rotate surface vectors to starting position / starting phase
- 3) Propagate & rotate surface vectors along SGP4 path
- 4) Calculate absolute values (distance from SGP4 path)

# CYLINDER PARAMETER VARIATION

Parameter variation: rotation axis / rotation phase (x: red, y: green, z: blue)

Assumption: Rotation around body fixed x-axis (red, no precession)

- 1) Cylinder initially defined along ECI z-axis [0,0,1] (blue)
- 2) Rotated around ECI y axis (green) -> **initial angle  $\Theta$**
- 3) Rotated around body fixed x axis to starting position -> **phase angle  $\alpha$**

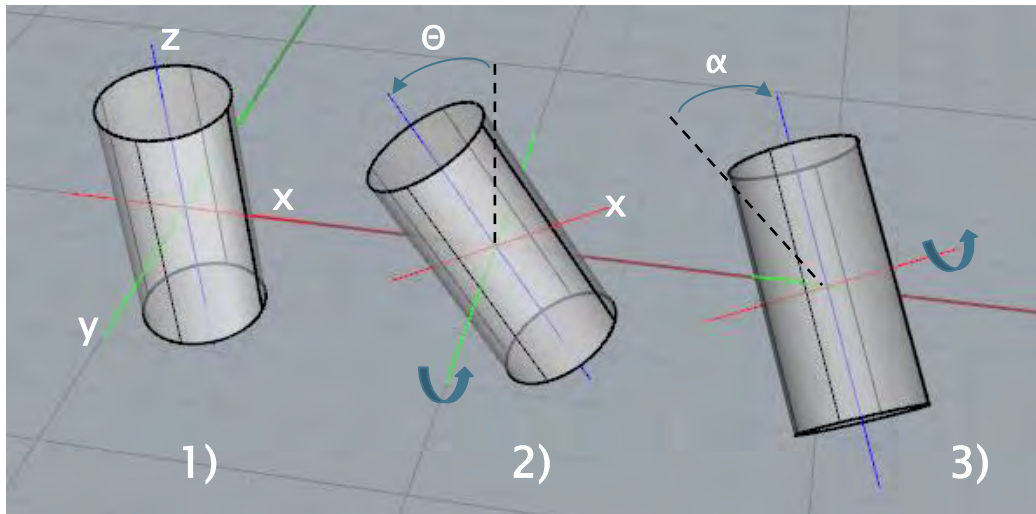

4) Cylinder rotated around body fixed axis while SPG4 propagated along orbit

Repeat 1) - 4) for  $360 \times 360 = 129600$  starting conditions for  $\Theta$  and  $\alpha$  / 1200 s each



# PARAMETER VARIATION: RESULTS

- 1) Light curve residuals (observed - simulated)
  - 2) Light curve x-overlap: x-offset peaks (observed - simulated)
- x-axis: phase angle:  $0-360^\circ$  / y-axis: initial angle:  $0-360^\circ$ , blue  $\rightarrow$  minimum

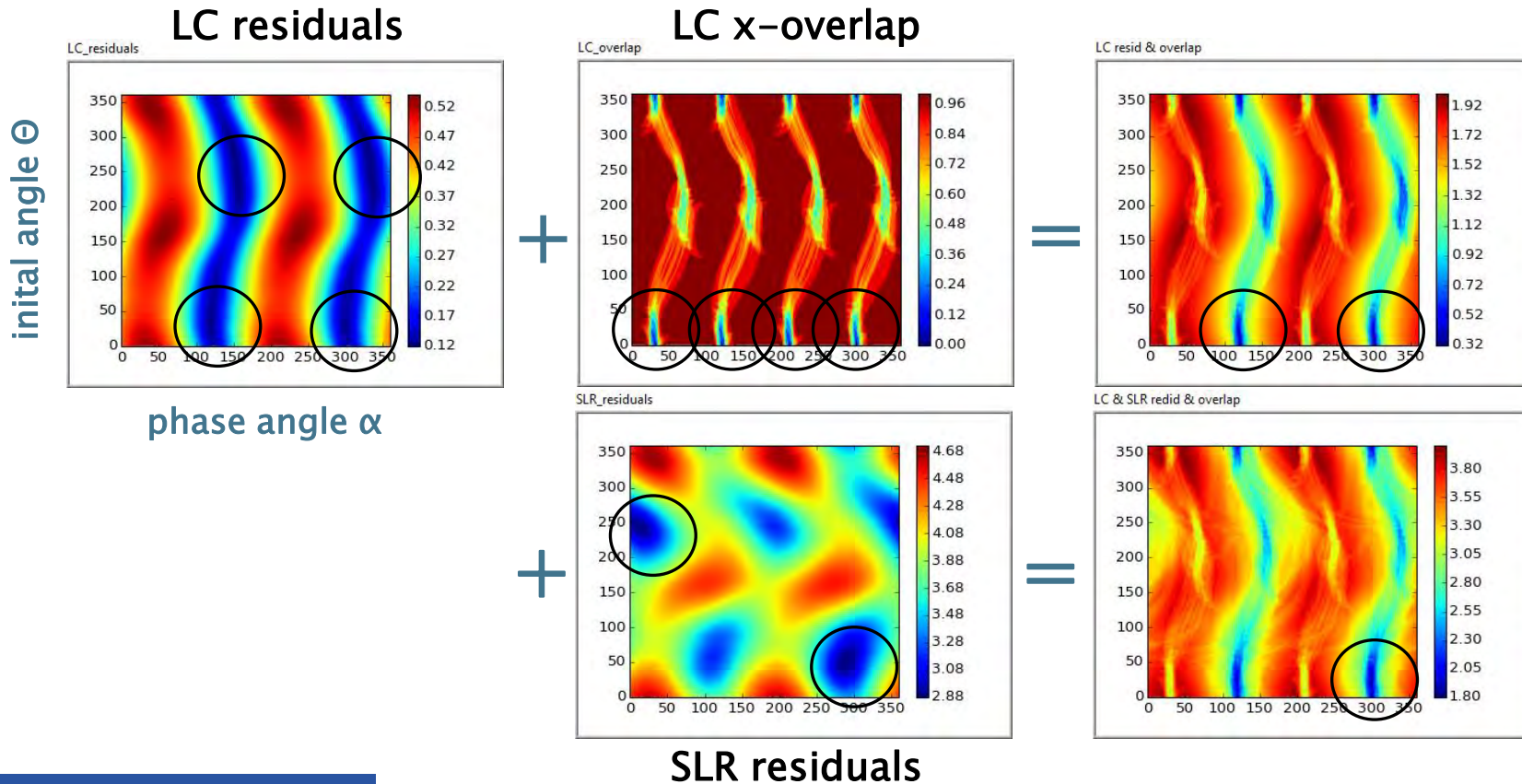

# RESULT LIGHT CURVE

- Initial angle  $\Theta = 31^\circ$  / phase angle  $\alpha = 299^\circ$

Measurement

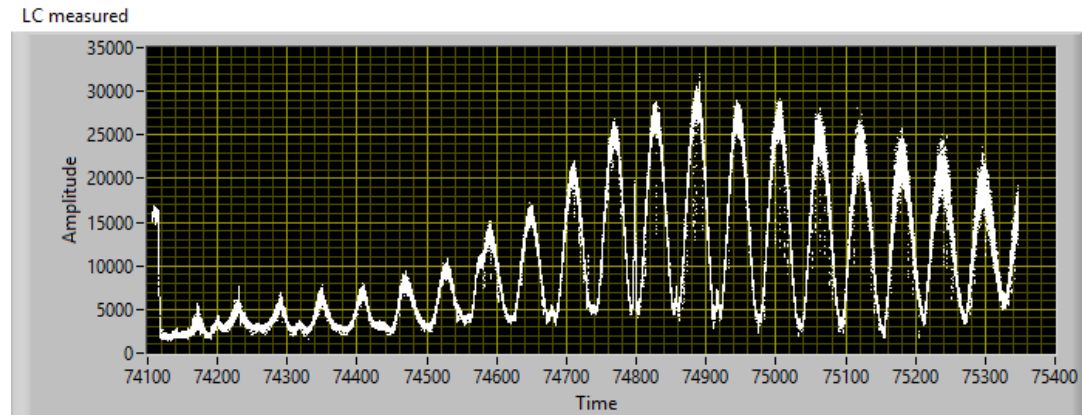

Simulation

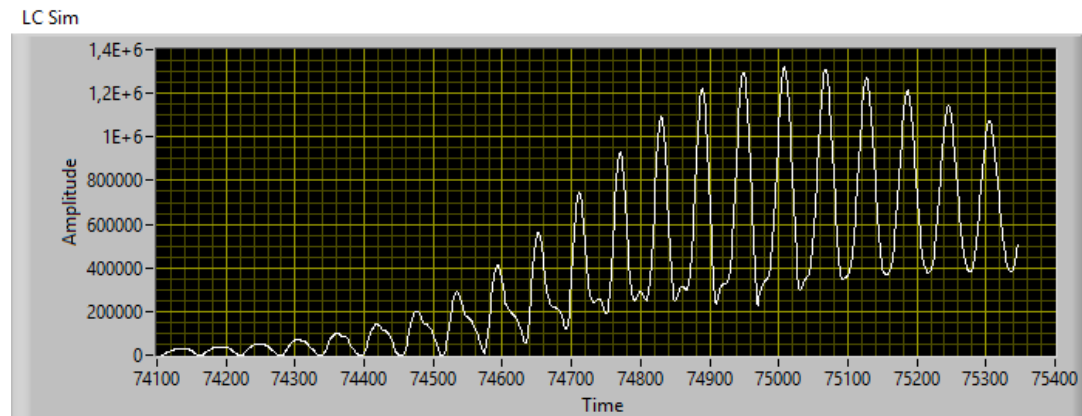

time

# RESULTS SLR

Initial angle  $\Theta = 31^\circ$ , Phase angle:  $299^\circ / 299^\circ - 180^\circ = 119^\circ$

SLR simulations include center of mass offset: -0.5 m along z-axis

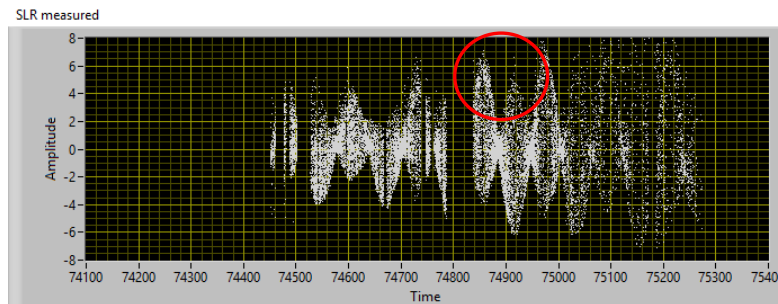

phase angle =  $299^\circ$

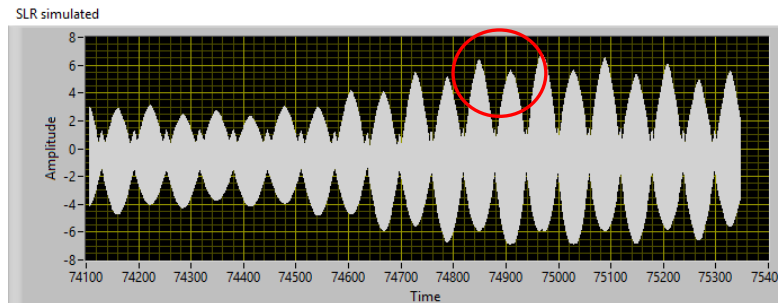

phase angle =  $119^\circ$

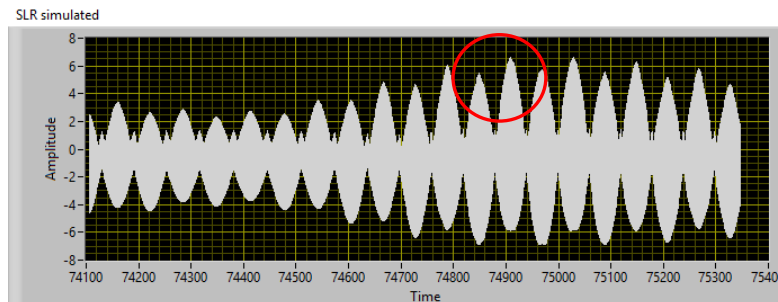

# SUMMARY

## Summary

- Simultaneous light curve and SLR measurements
- Target: large upper stage rocket body
- Comparison experiments with simulations
- Analysis based on only one set of measurements each
- Draw conclusions on rocket body orientation along path

## 2 DOS

- Extend parameter range to broader / full set of rotational planes
- Refine rocket body model
- Find rotational axis in ECI
- Work in progress -> inputs, thoughts, ideas

! Use the light gathered by your telescope which is not needed for SLR !

# THANK YOU

# Towards satellite shape recognition with Graz Single Photon Counting System

Daniel Kucharski <sup>1\*</sup>, Georg Kirchner <sup>2</sup>, Franz Koidl <sup>2</sup>, Peiyuan Wang <sup>2</sup>, James C. Bennett <sup>1</sup>,  
Toshimichi Otsubo<sup>3</sup>, Hiroo Kunimori <sup>4</sup>, Krzysztof Sośnica <sup>5</sup>, Francesco Vespe <sup>6</sup>

1) Space Environment Research Centre, SERC, Mount Stromlo, Australia

\*) [danielkucharski@serc.org.au](mailto:danielkucharski@serc.org.au)

2) Space Research Institute, Austrian Academy of Sciences, Graz, Austria

3) Hitotsubashi University, Tokyo, Japan

4) National Institute of Information and Communications Technology, Tokyo, Japan

5) Institute of Geodesy and Geoinformatics, Wrocław University of Environmental and Life Sciences, Wrocław, Poland

6) Agenzia Spaziale Italiana, Centro di Geodesia Spaziale "G. Colombo", Matera, Italy

# Complex dynamics of space debris objects

The passive, defunct satellites gain spin energy from the environment.

The spin parameters change over time mainly due to:

- solar radiation pressure
- magnetic field interaction
- gravitational torque

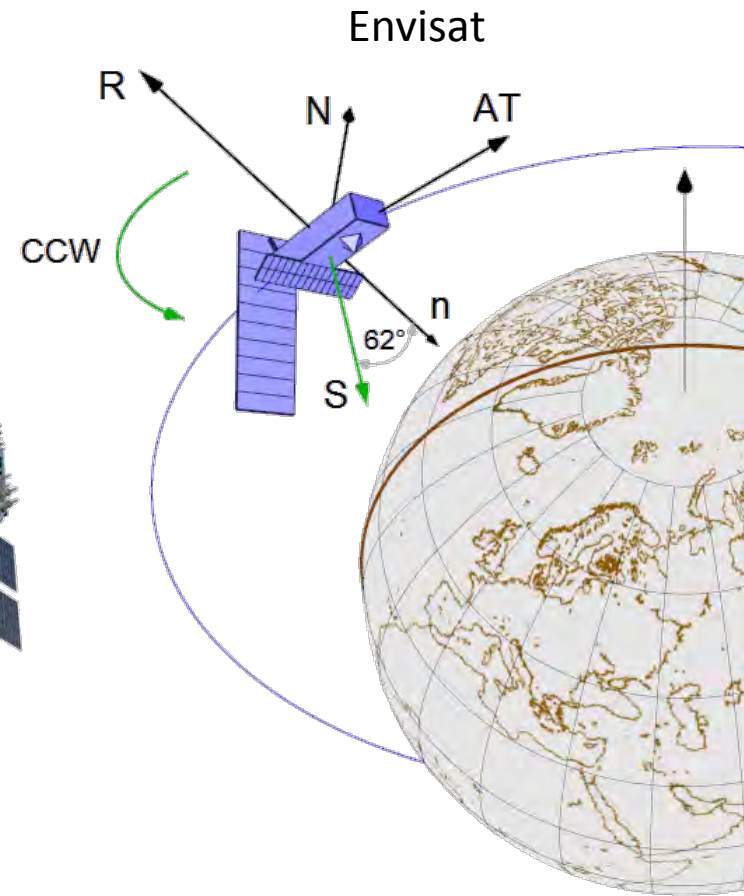
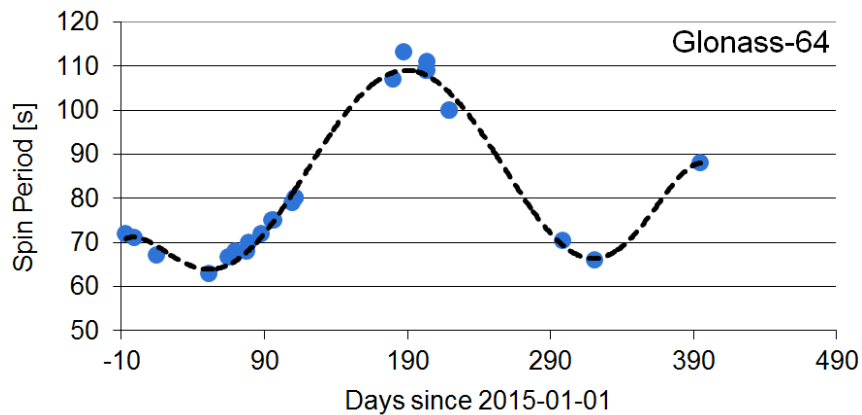
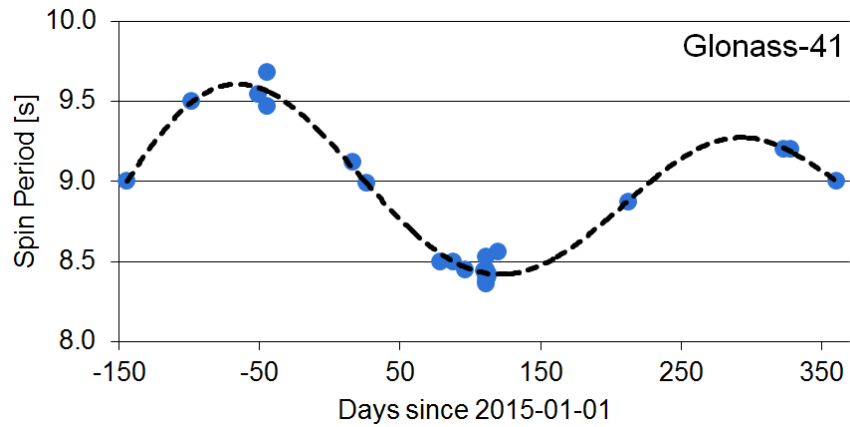

# Spin measurement with optical methods

Graz satellite tracking system simultaneously performs laser ranging and light curve measurements (since 2015).

The light curves allow for the spin determination of all satellites, including uncooperative targets - with no CCRs.

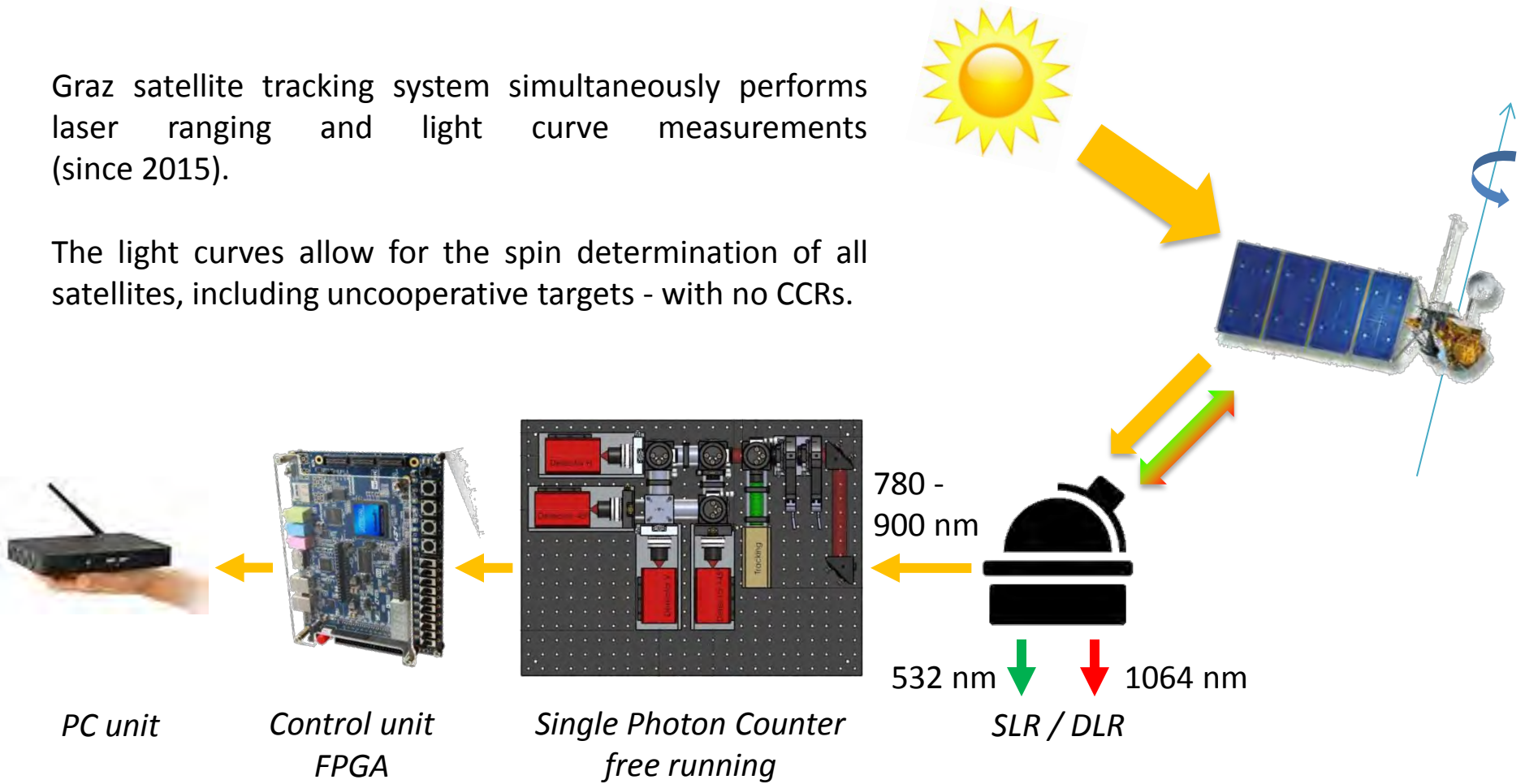

The free running photon counter allows to achieve kHz sampling rates of the reflected solar flux.

# Spin determination with light curves

Spinning TOPEX/Poseidon light curve

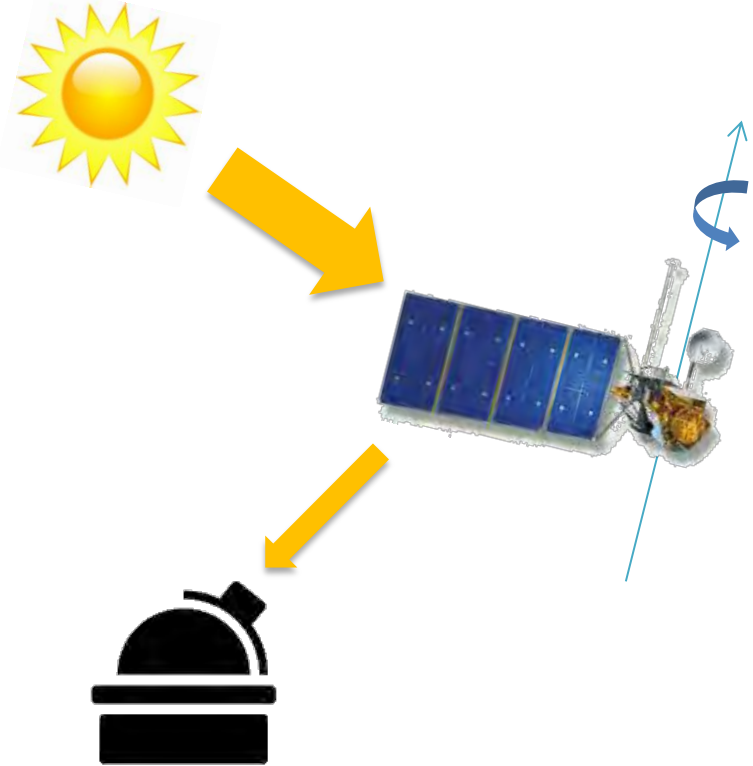
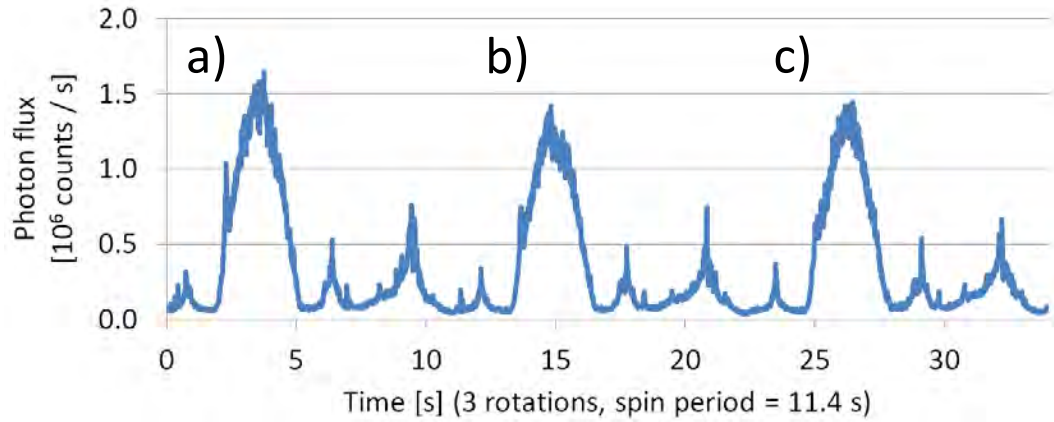

Phase  
Dispersion  
Minimization

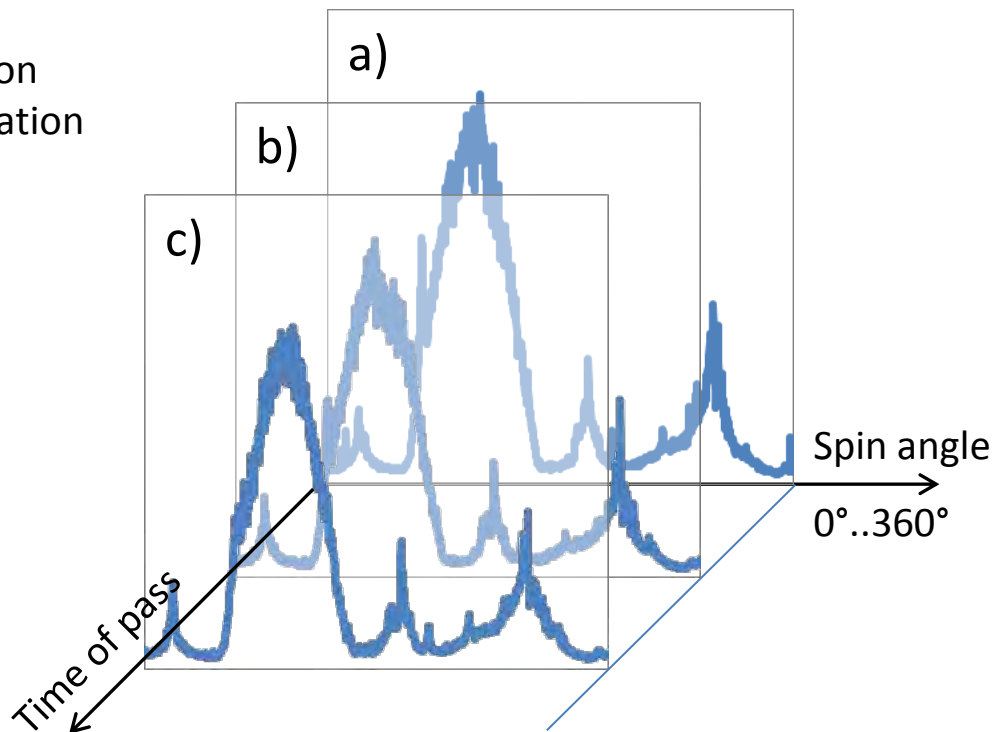



# Single photon light curves

Spinning TOPEX/Poseidon light curve

- full pass, 57 rotations (11 minutes)
- mix of specular and diffuse reflections from different sides of the spinning body
- perfect for accurate spin determination if the satellite body shape is known

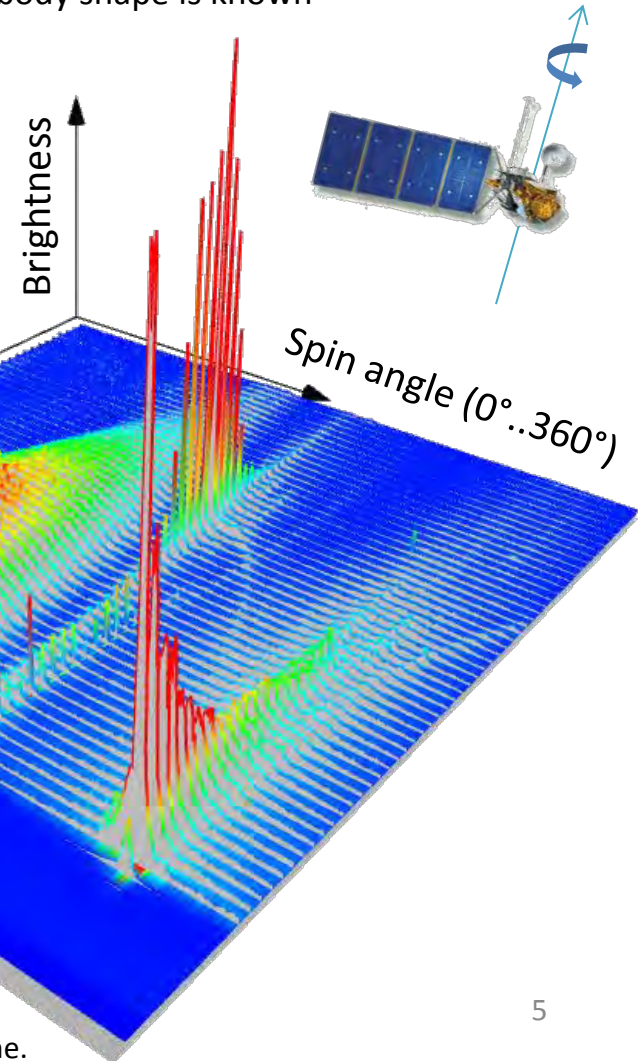
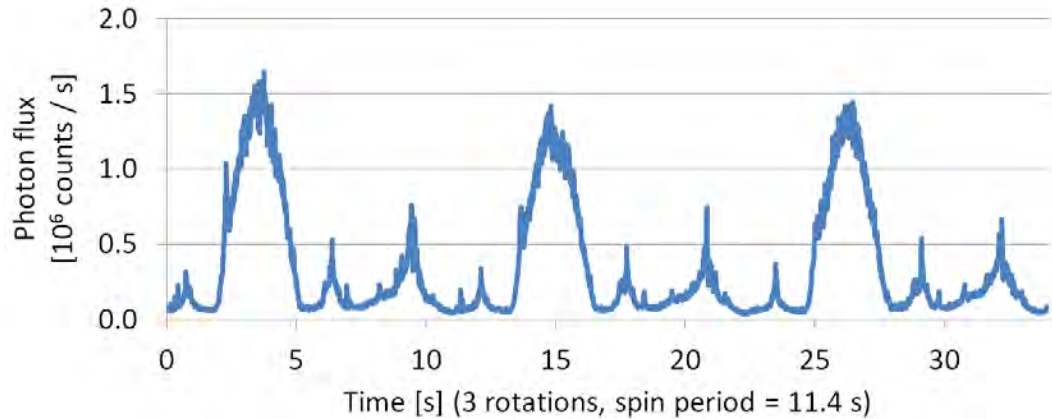

Our challenge:  
identify satellite shape by reverse flash analysis

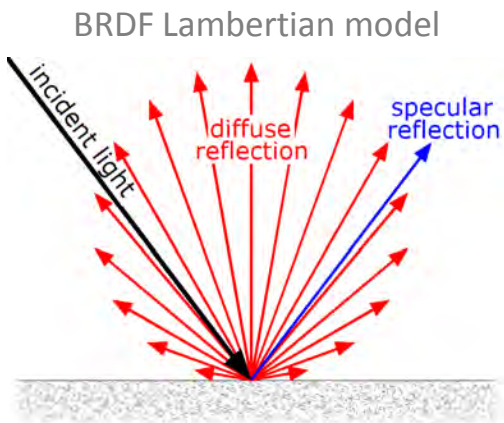

# Single photon light curves – flashes from mirrors

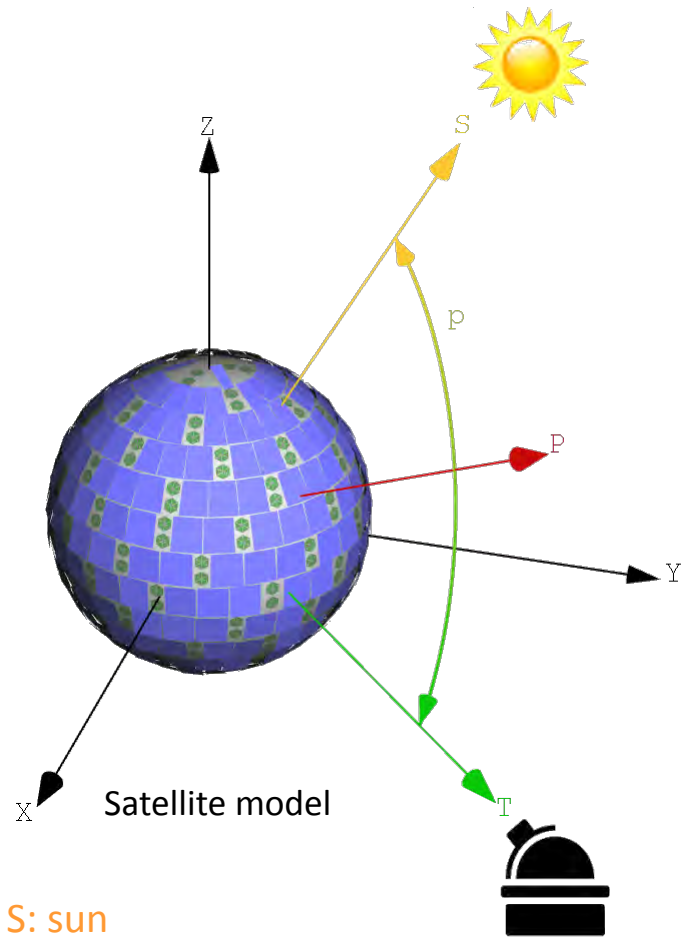

**S:** sun  
**T:** telescope  
**P:** phase vector =  $S + T$   
**p:** phase angle  
**i:** inclination angle

- Shape recognition of a box-wing type satellites is a difficult task
  - Start with the analysis of the specular reflections from Ajisai:
    - 1436 CCRs for SLR = cover 6.6 % of the body surface
    - 318 mirrors = cover 72.7 % of the body surface
- Almost 80% of Ajisai is covered by reflective elements.

Spin parameters of Ajisai are well known and accurately modeled:

- spin axis aligned with Earth rotational axis
- spin period  $\sim 2.3$  s

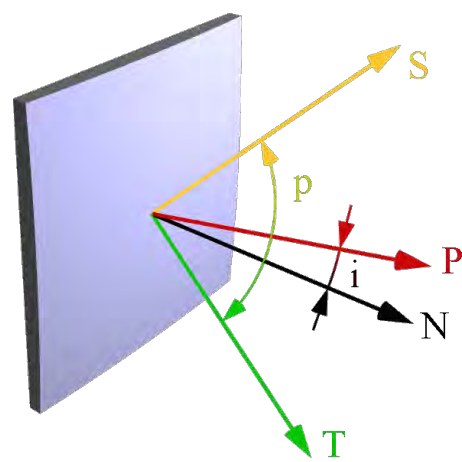

A single mirror

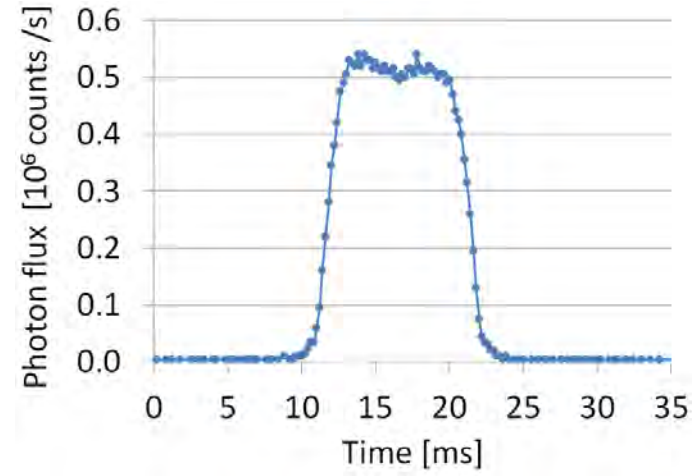

Sun flash from a mirror

# Photometric pass of Ajisai

April 4, 2016

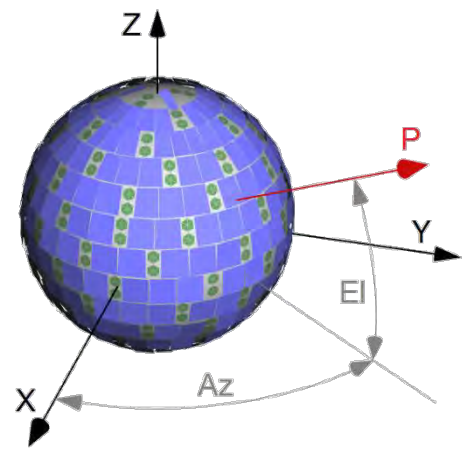
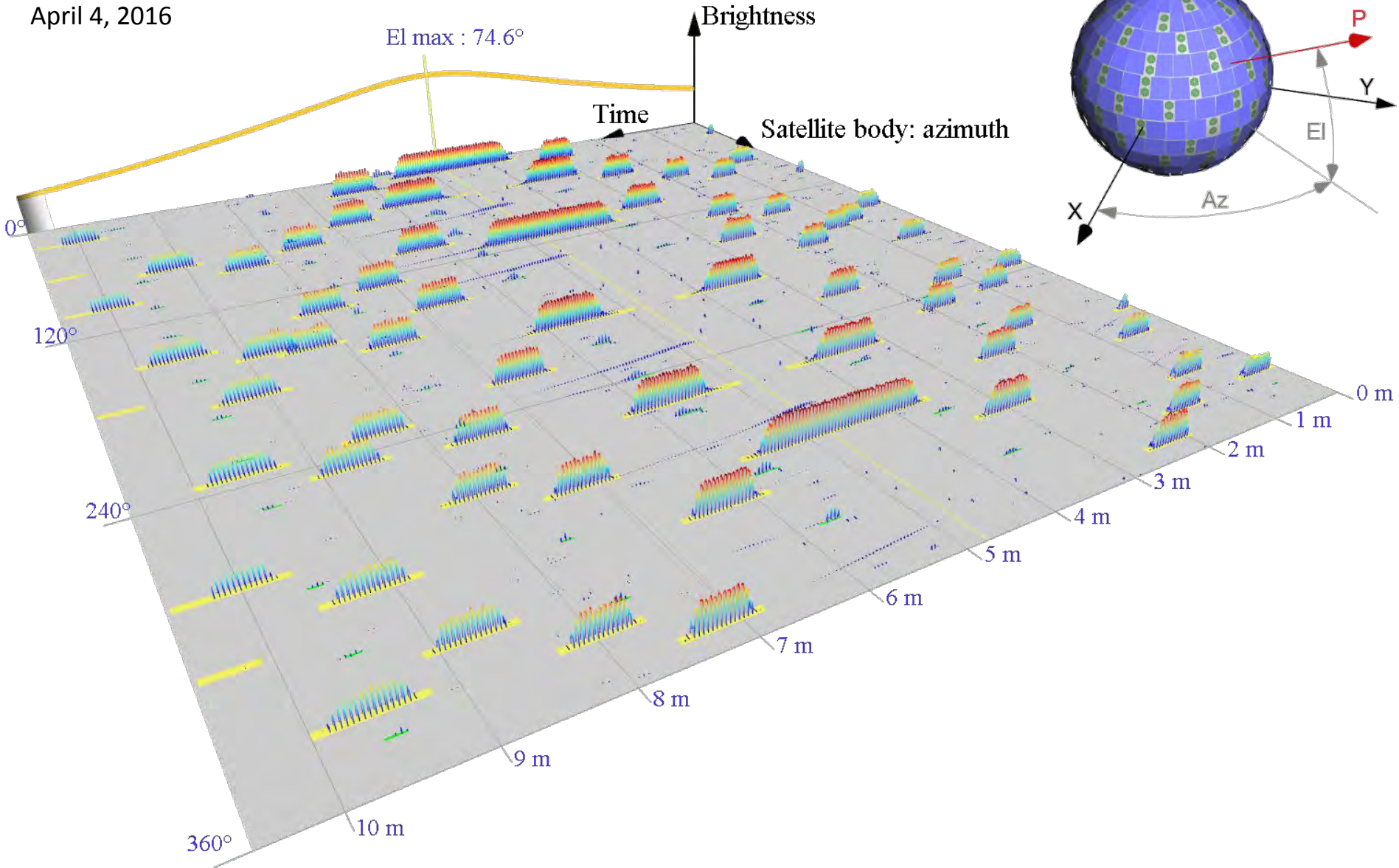

# Photometric pass of Ajsai

April 4, 2016

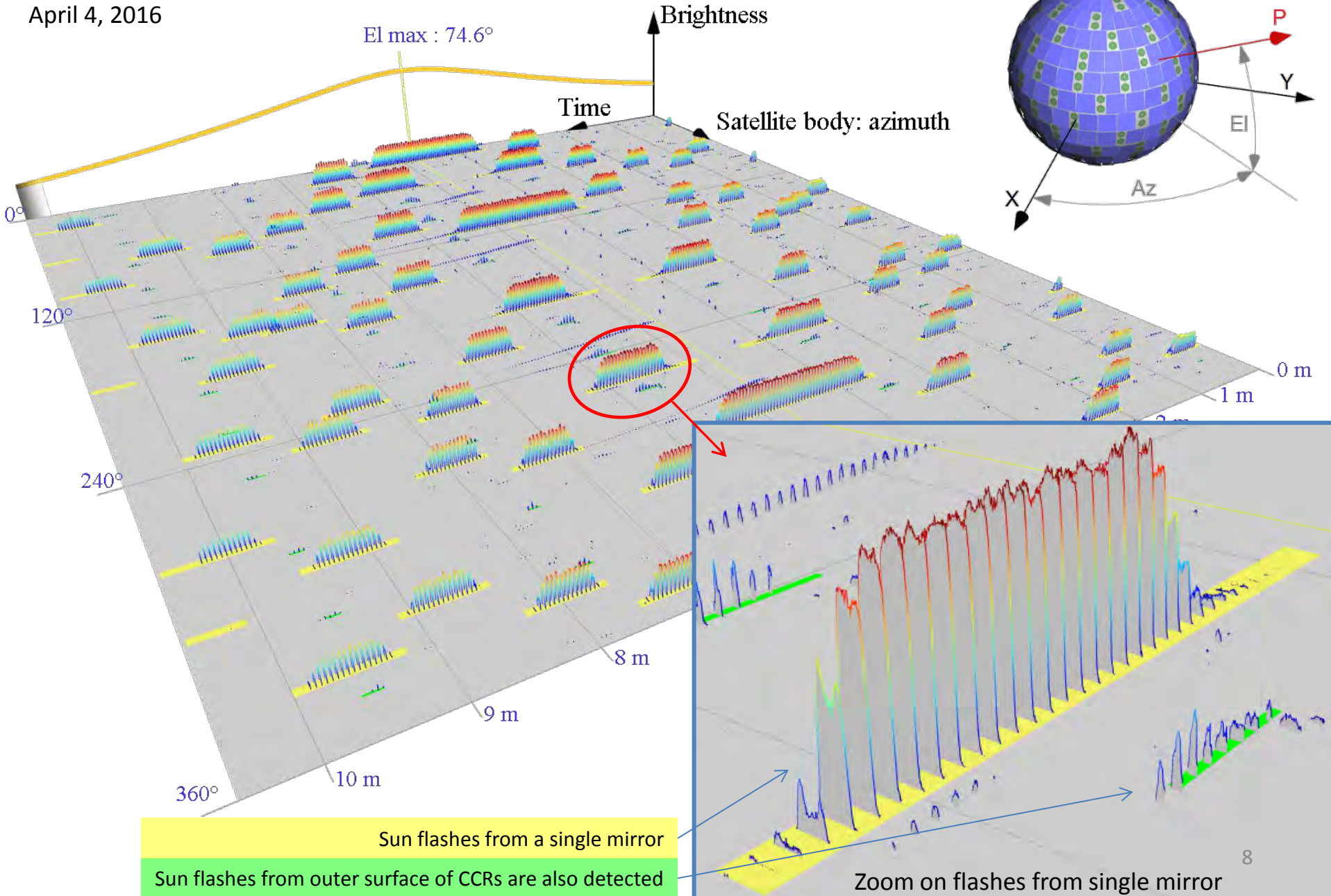

# Flash burst from a single mirror

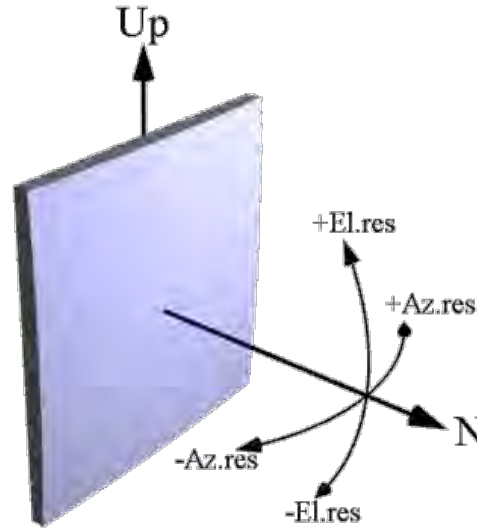
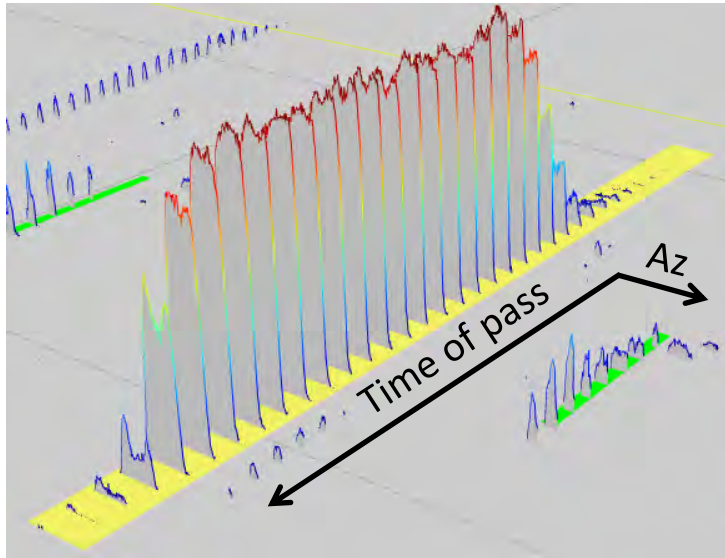

The mirror surface is curved thus the inclination angle between the phase vector and the surface normal changes during a single flash.

The orientation of the phase vector with respect to the surface central normal can be expressed by the azimuth and elevation residual angles.

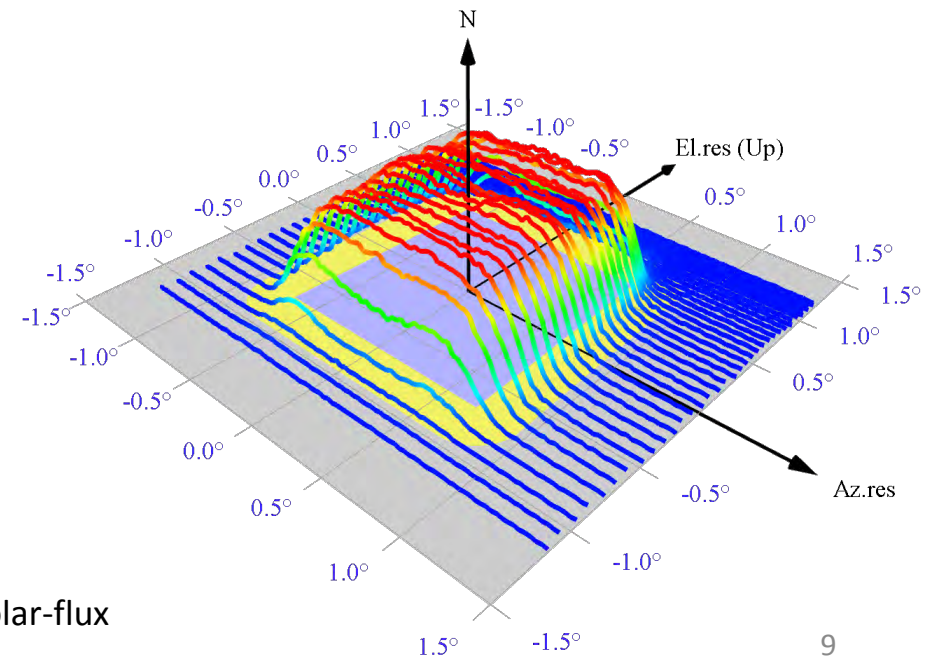
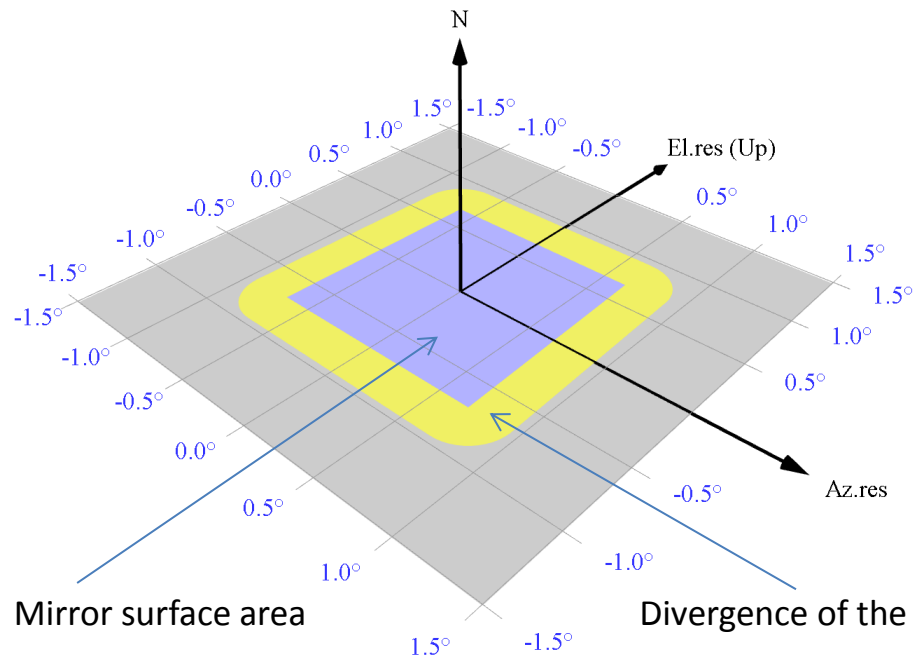

# Surface reflectivity profile – a single mirror

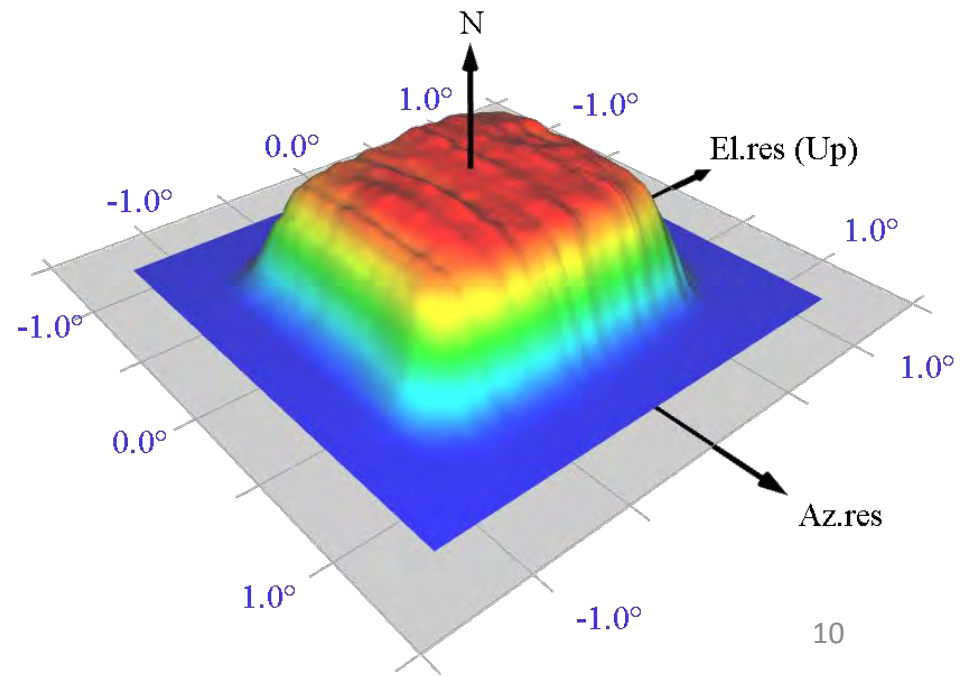
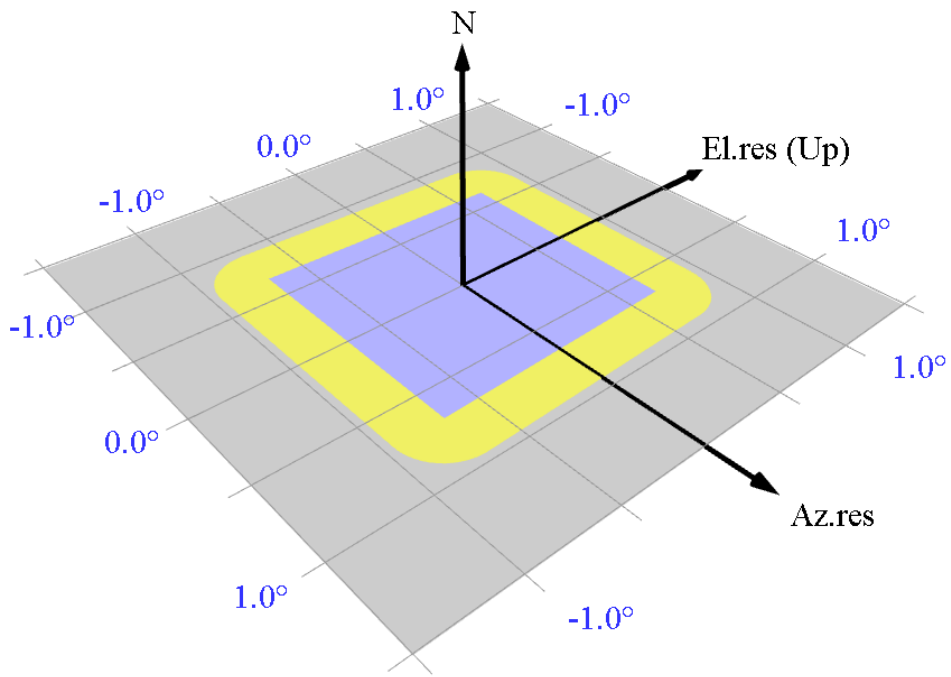
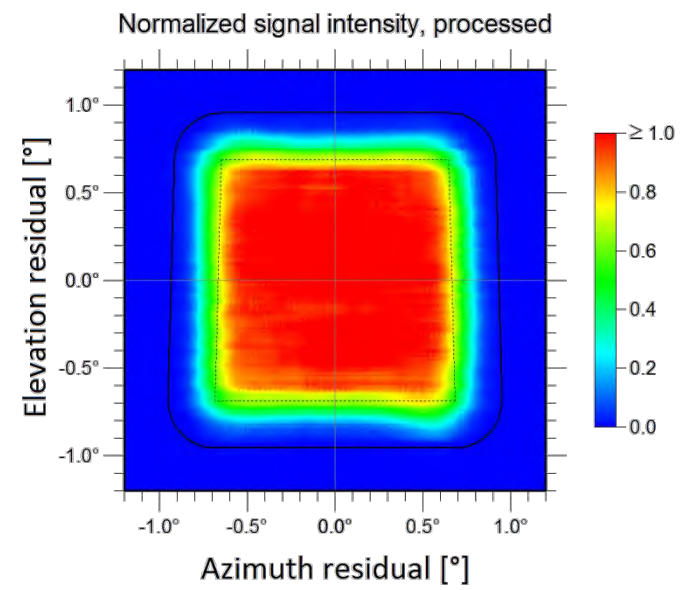
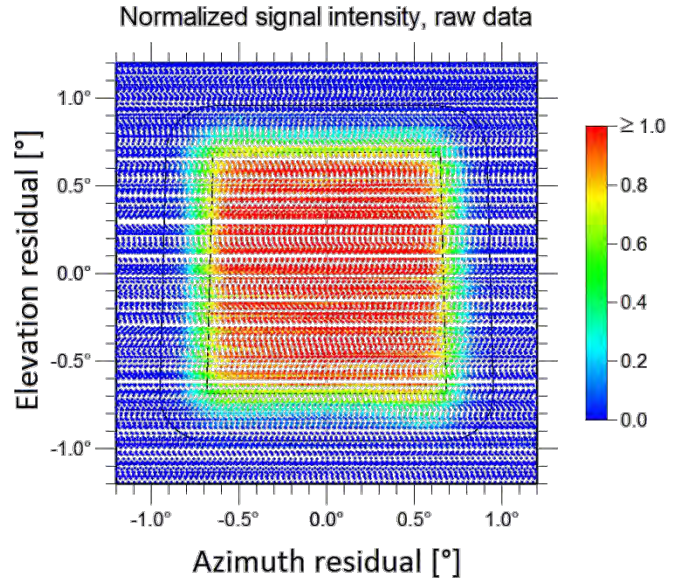

# Surface reflectivity profile – multiple mirrors

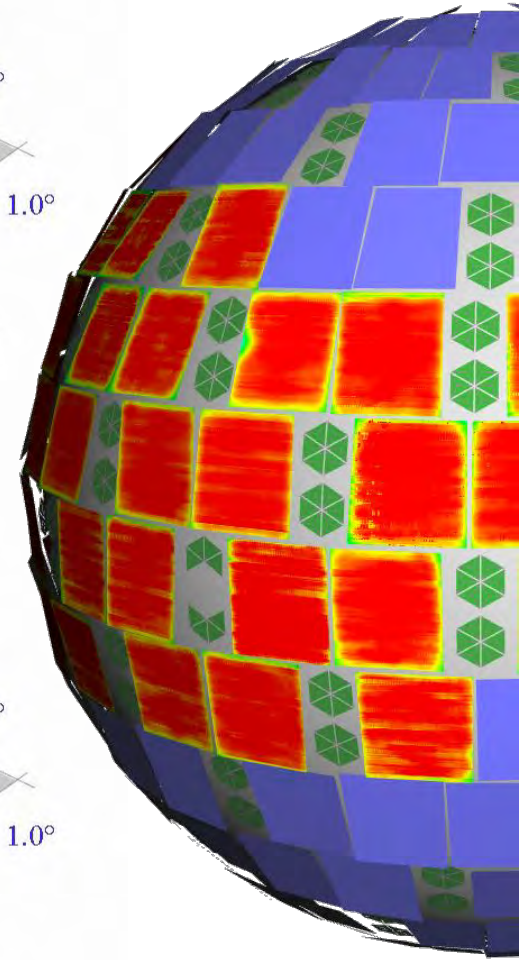
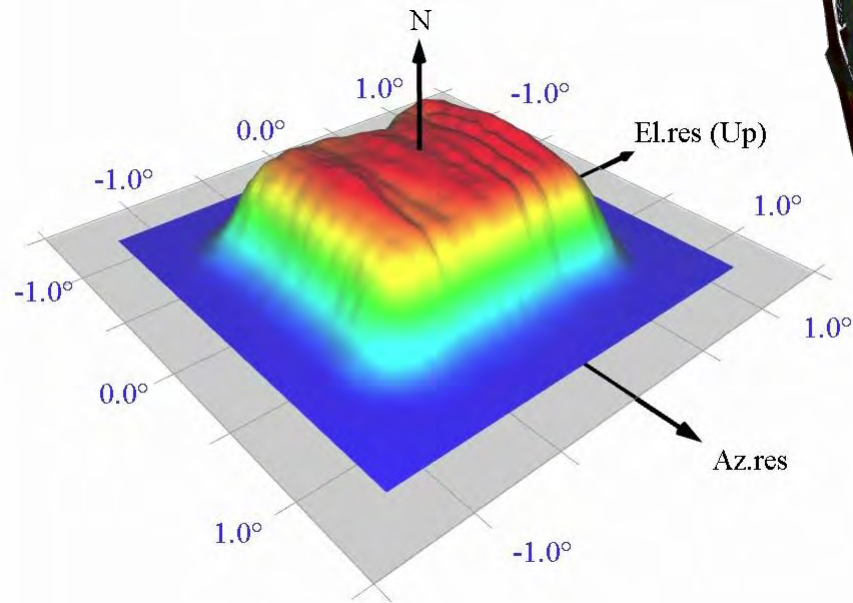
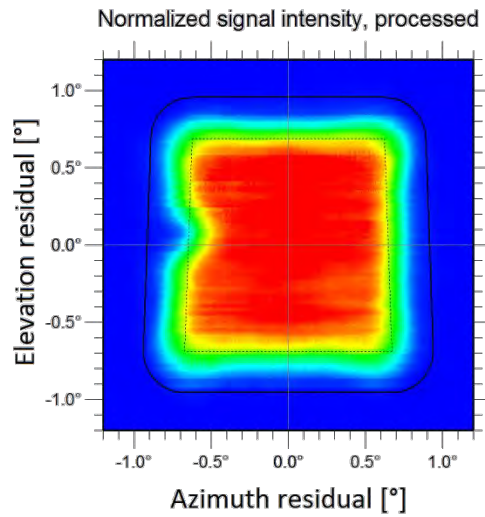
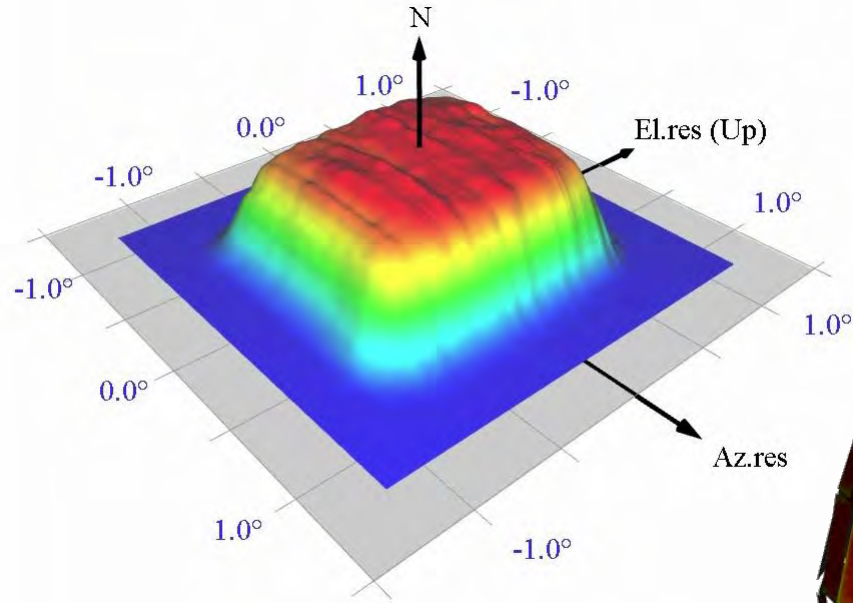
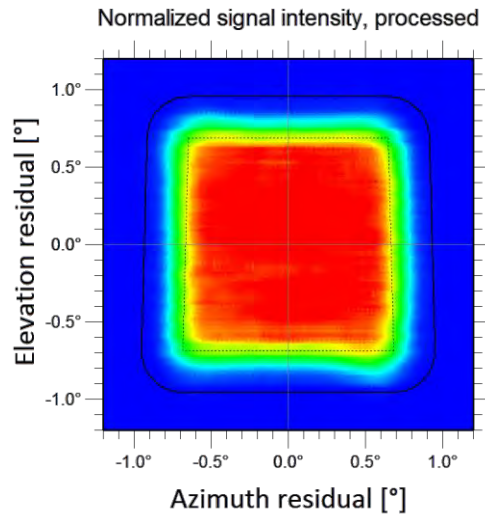

- The Single Photon Counting System is an automated add-on to the SLR telescope and can work in parallel without disturbing the regular laser ranging
- The experience with Ajisai opens the way for the development of the complex satellite shape recognition algorithm from the combination of the specular and diffuse reflections
- The photometric observations from multiple ground locations are necessary for the efficient space debris characterization: spin determination, shape recognition...

Let's build a photometric network!

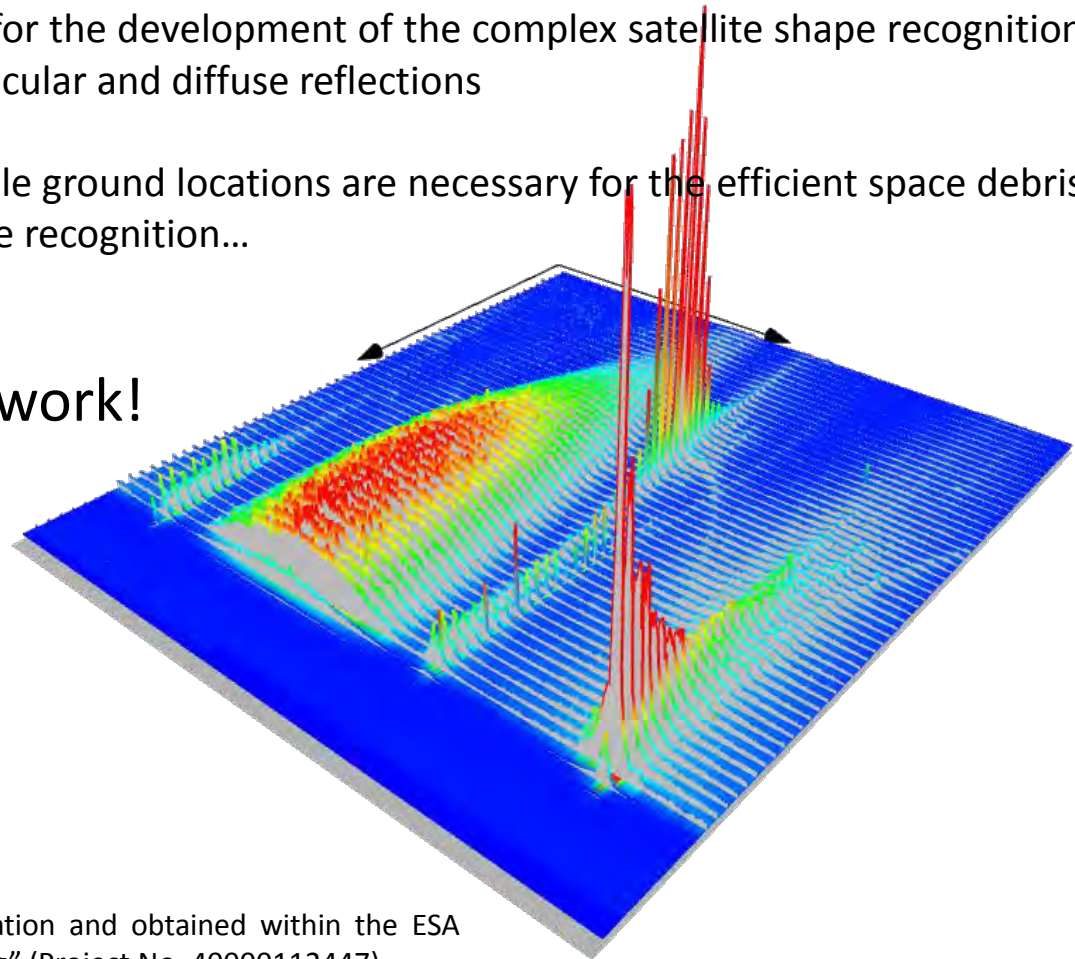

We acknowledge the use of data provided by Graz SLR station and obtained within the ESA project "Debris Attitude Motion Measurements and Modelling" (Project No. 40000112447). This research is supported by the Cooperative Research Centre for Space Environment Management, SERC Limited, through the Australian Government's Cooperative Research Centre Programme.



# An analysis of the close approach between Jason 2 and Topex/Poseidon

James Bennett



Australian Government  
Department of Industry and Science

**Business**  
Cooperative Research  
Centres Programme

## Jason 2 + Topex / Poseidon close approach

- Close approach occurred on June 20<sup>th</sup> 2017 at 04:40 UTC;
- Initial prediction indicated 400 m close approach.
- Triggered emergency tracking campaign through the SDSG (June 30<sup>th</sup>):
  - Frank Lemoine, Georg Kirchner, ...
- Jason 2 subsequently manoeuvred;
- Low relative velocity: 80 m/s

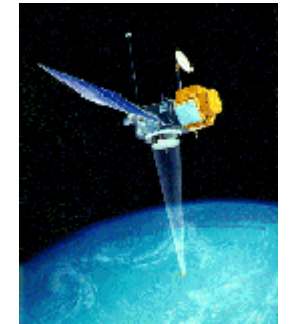

Intl. Des.	Norad ID	Name	Launch date	Period	Inclination	Apogee	Perigee	Mass	RCS
1992-052A	22076	TOPEX/POSEIDON	10/08/1992	112.4	66	1344	1331	2388	7.79
2008-032A	33105	JASON-2 (OSTM)	20/06/2008	112.4	66	1344	1331	553	3.1623

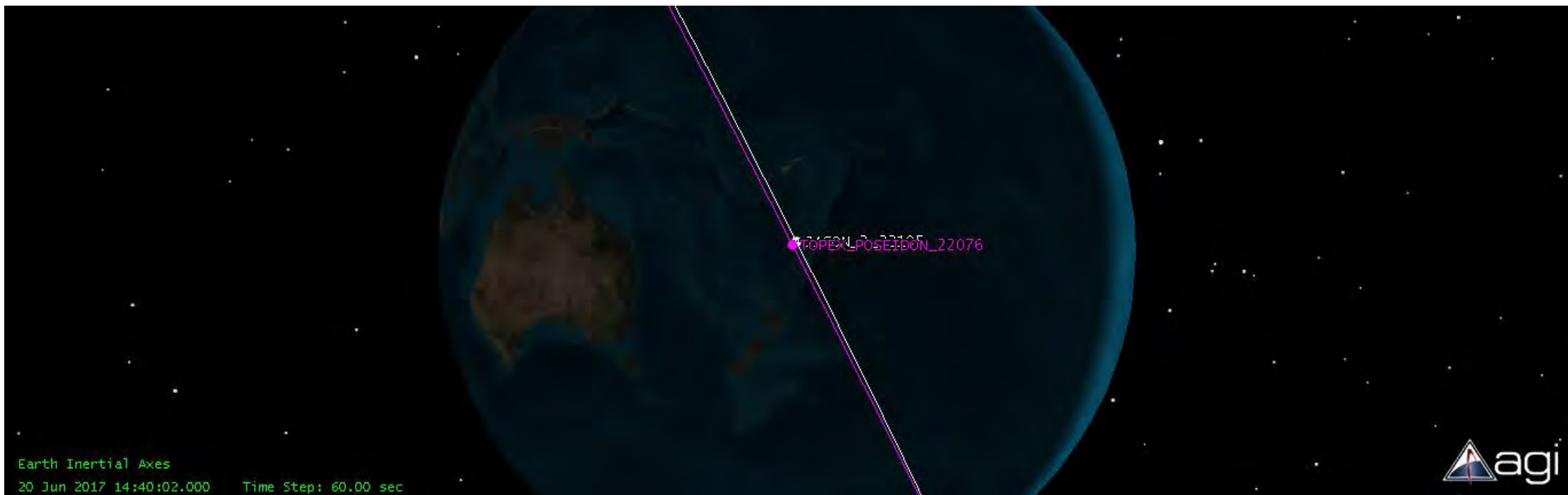

## Miss distance calculations

- Ranging data from the SDSG was fitted prior to the close approach and the miss distance was calculated.
  - Simple spherical satellite body models for T/P and Jason 2.
  - Dominant perturbing forces modelled.
- This was then compared with the close approaches calculated from the TLE data.
  - All-on-all conjunction assessments was performed on multiple TLEs.
  - Assess the variability of differing TLEs.



# Results from the orbit determination

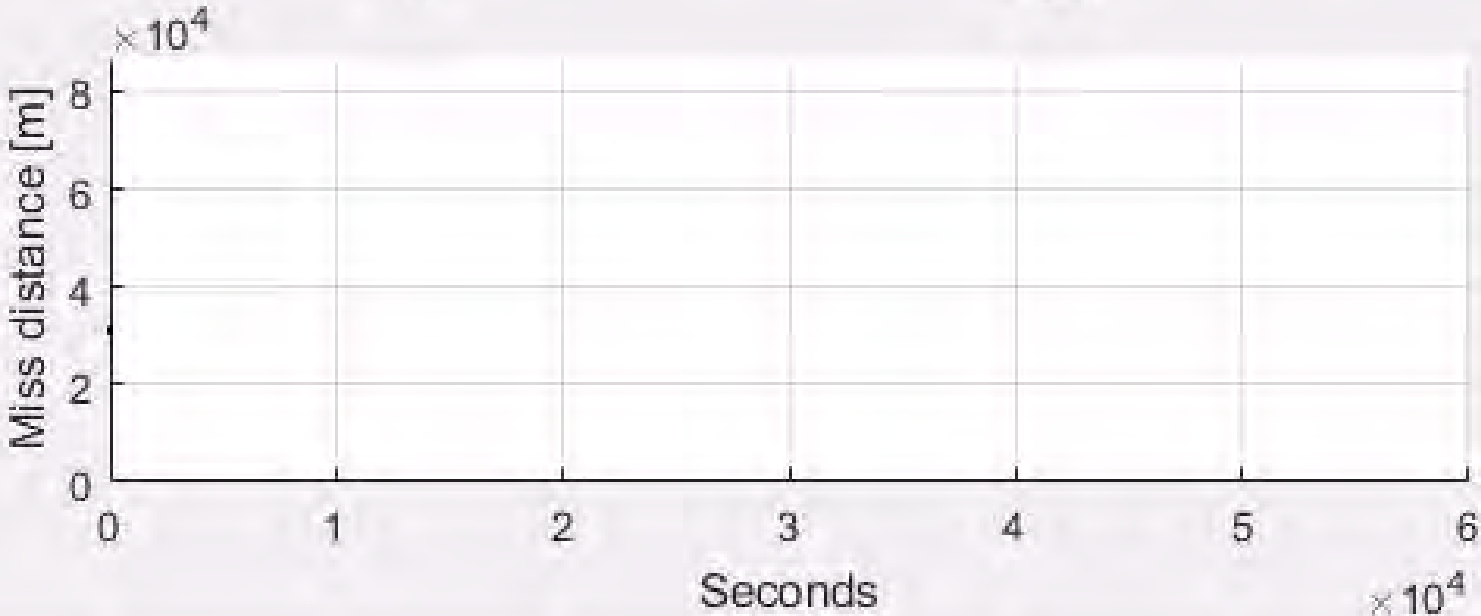
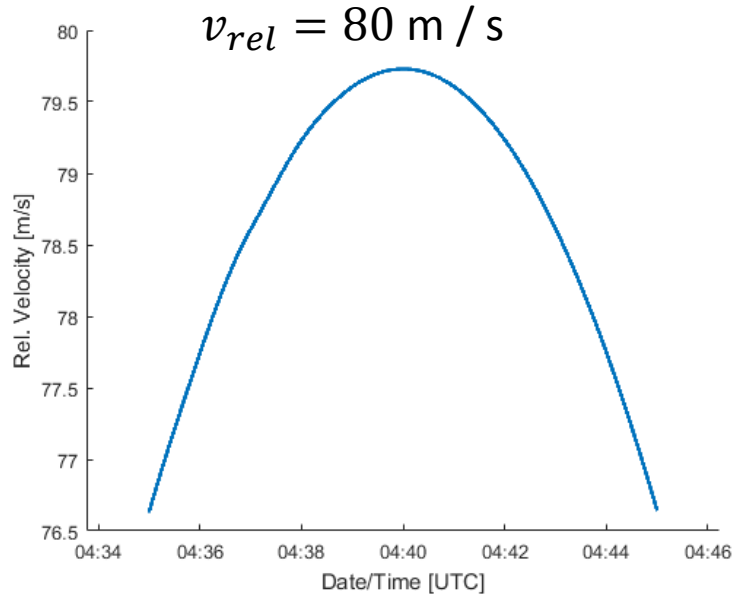
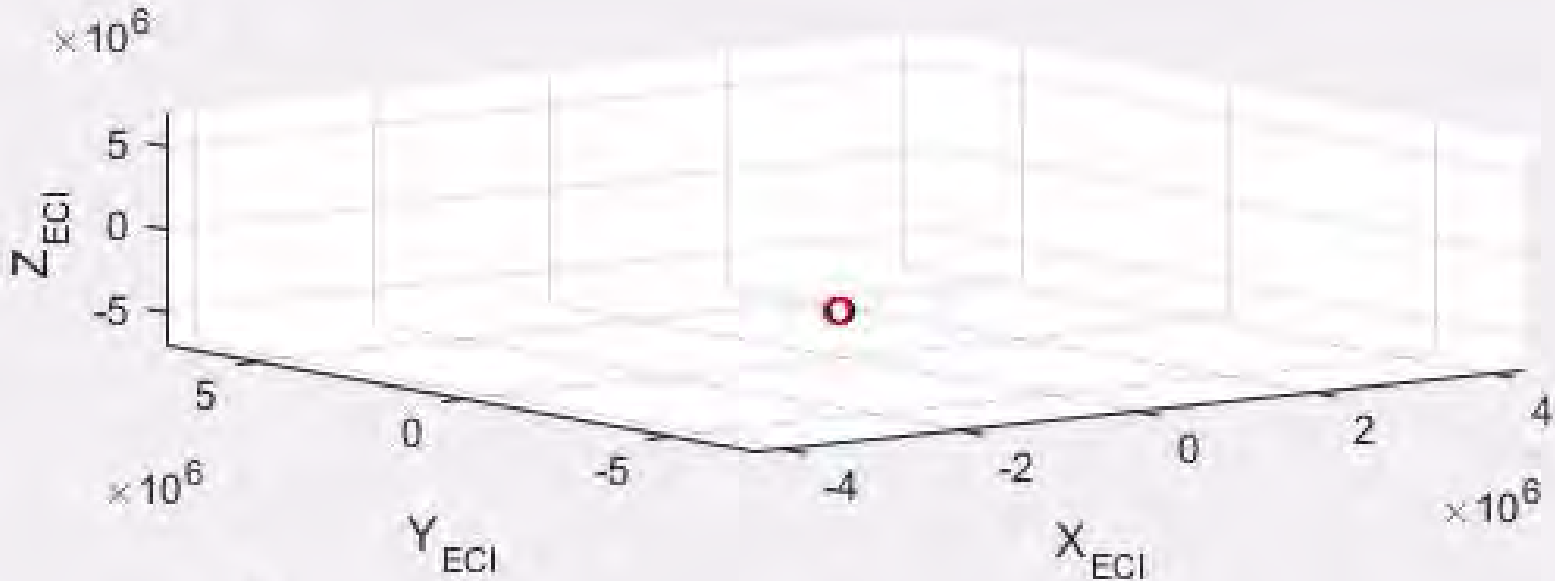

TCA:  
20-Jun-2017 04:40:02

Non-catastrophic environmental impact  
Catastrophic science impact



# TLE close approaches – All-on-all using multiple TLEs

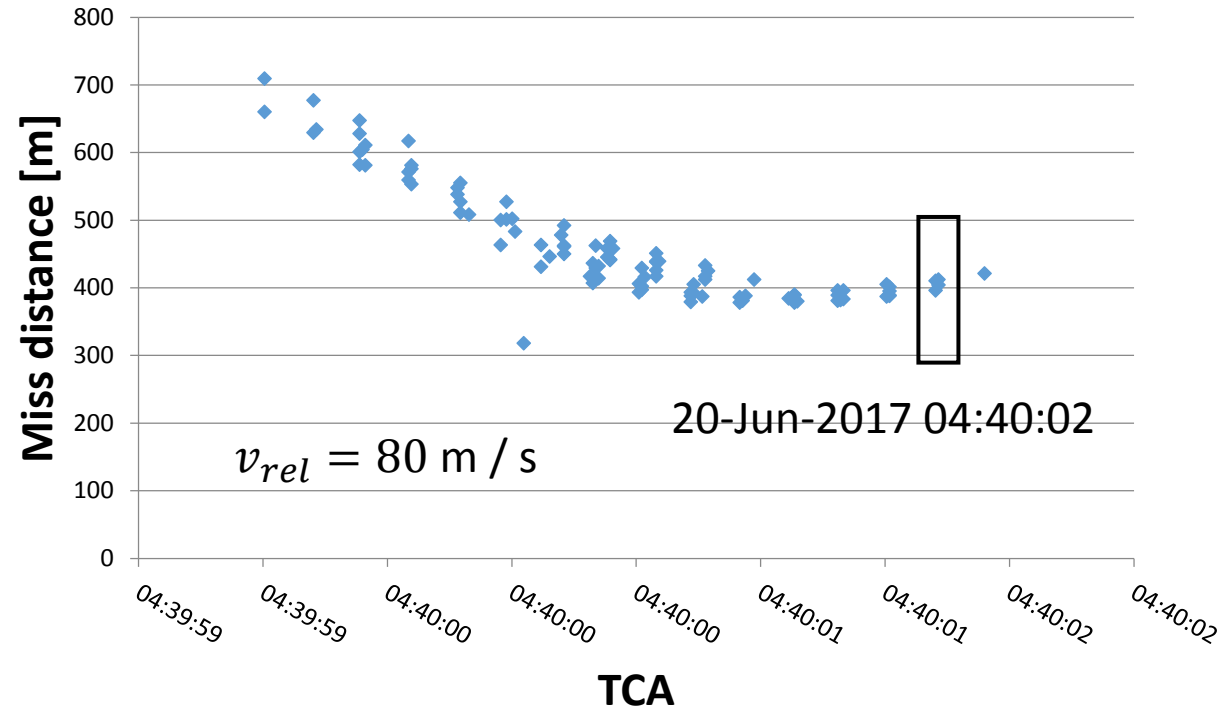
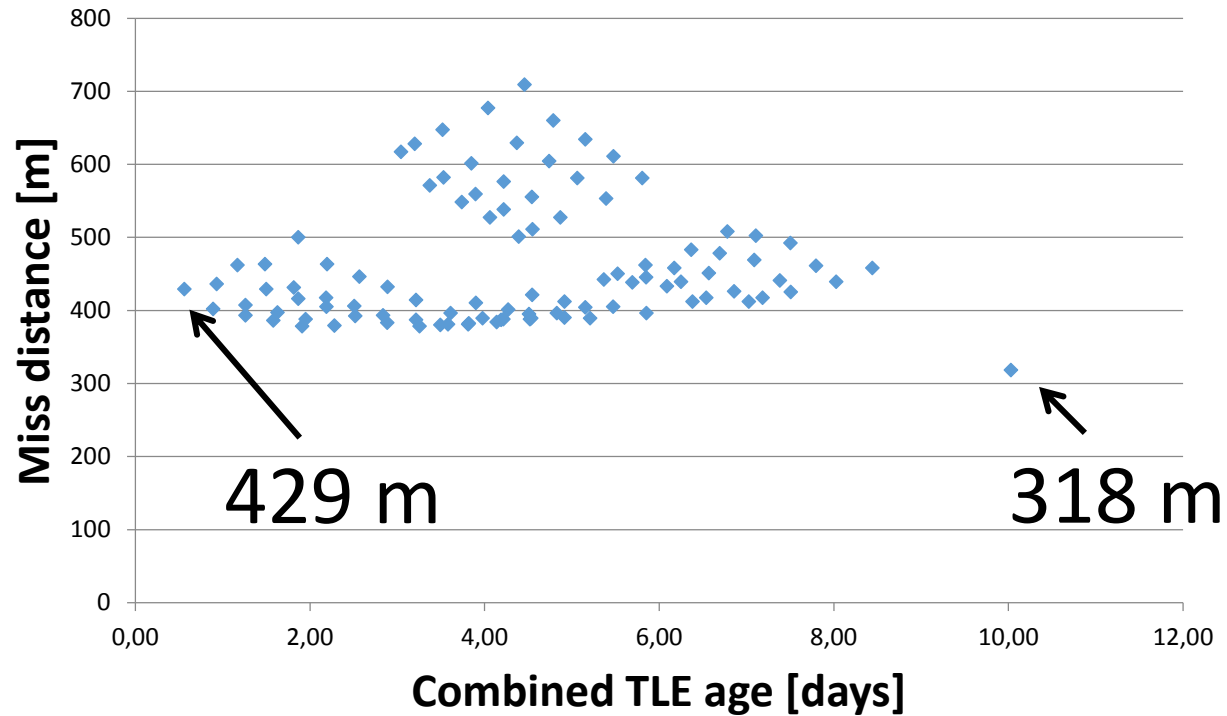

- Predicted close approach using TLEs immediately prior predicted 429 m, TLEs 5 days prior predicted 318 m.
- TCA similar from both methods.
- OD fitting SLR data predicted 365 m.

## Summary

- The close approach calculated from the TLE data *in this case* was representative of the miss distance.
  - If the latest TLE calculations were used then the miss distance was larger... Iridium/Cosmos collision.
- The close approach had a low relative velocity
  - Non-catastrophic environmental impact;
  - Very catastrophic scientific impact;
- Debris laser ranging can play an important role in conjunction assessments and space situational awareness.
  - Precision follow-up measurements.
- Are the JSpOC predictions good enough for satellite operators?
- Analysis can be improved by implementing better satellite body models
  - Daniel Kucharski's work.



# Example: Iridium 33 Cosmos 2251 collision

- February 10th 2009 Cosmos 2251 and Iridium 33 collided at an altitude of 789 km;
- Close approach was predicted to be over 500 m only hours before the conjunction;

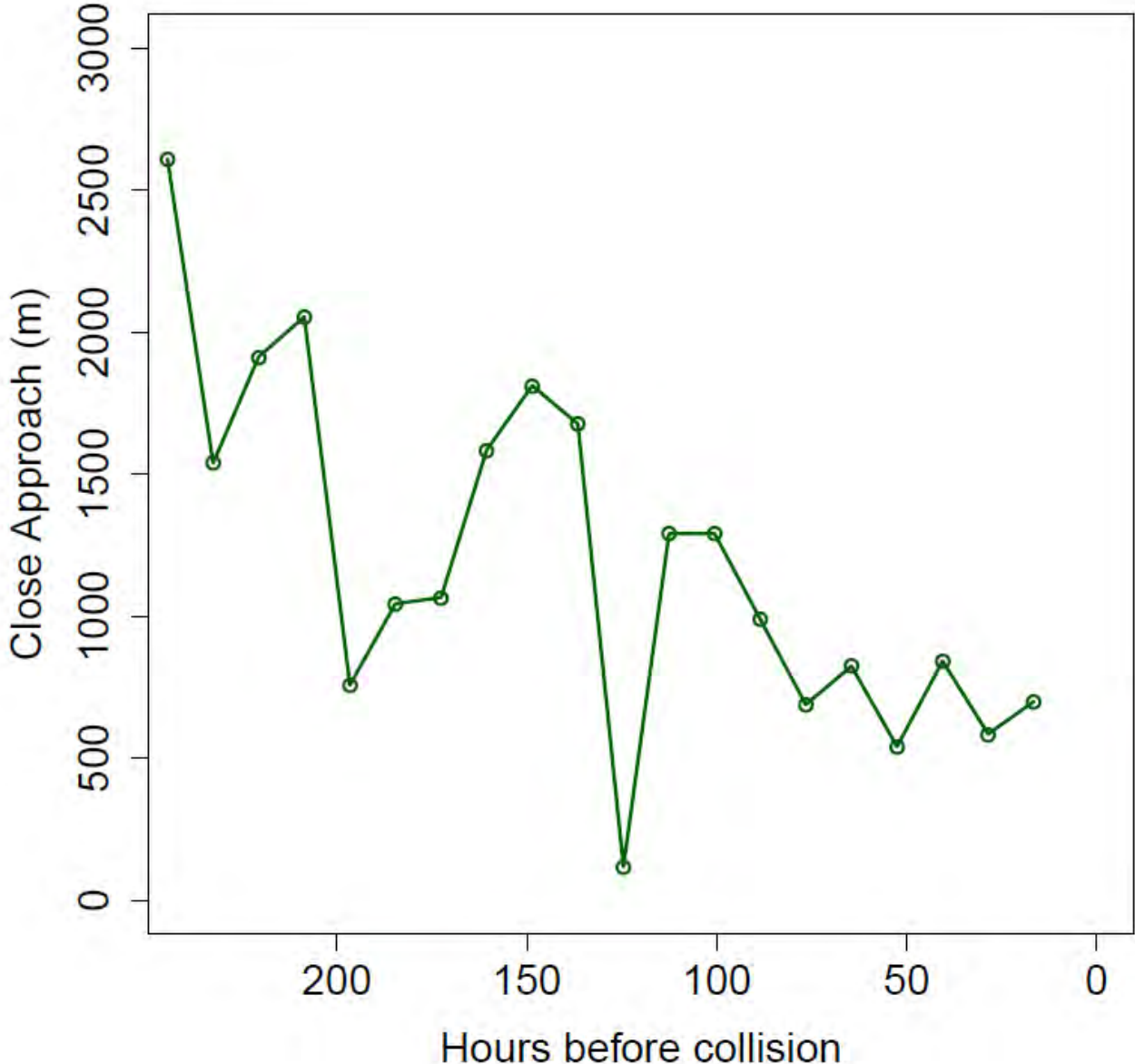
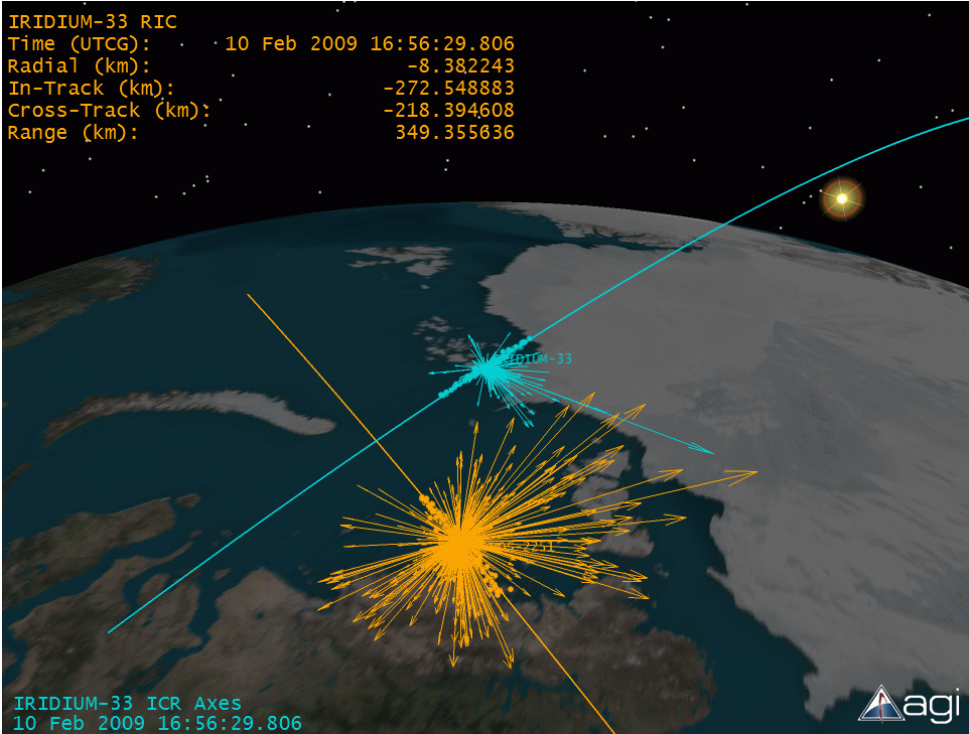



# Talking points

- Why lasers for space debris tracking?
  - Precision measurements, better orbit predictions.
- What are the concerns with space debris tracking in the ILRS?
- Georg's cost analysis.
- Should the ILRS track satellites after the mission ends? A role for SDSG? Better SSA.
- Conjunction assessments
  - Long encounter times provide challenges.
  - Do radars do the job?
    - Iridium Cosmos collision
  - Predictive rather than reactive
- EOS have been ranging to uncooperative targets for over 15 years.
  - R&D has led to operational space debris laser tracking station, deployed in WA. More sites to follow.
- Working with US SSN, data has been assessed and accepted. LCH approval.
  - Radar: all weather, coverage.
  - Lasers: weather restricted, precision updates.
  - No single tracking technology provides the solution.
- Atmospheric mass density modelling. SERC is working on improving these models.



# Site map

WA site is a project between EOS Space Systems & Lockheed Martin with support from AUS DoD;

Installation of optical + laser tracking systems located in Western Australia (3,500+ km from Mt Stromlo);



# Research Program 3: Space Asset Management

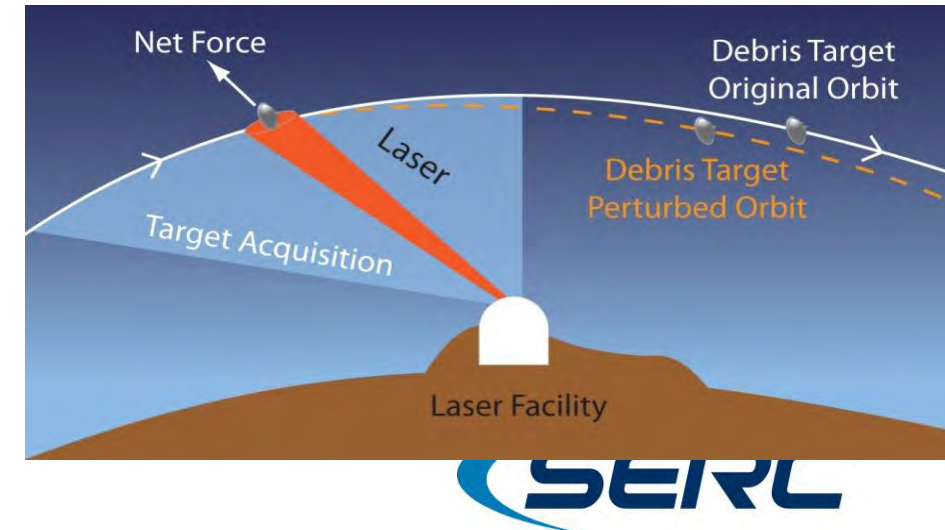
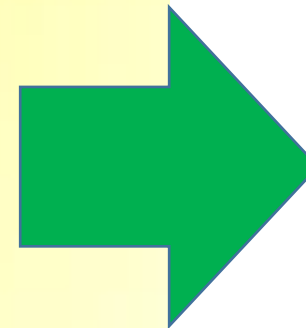
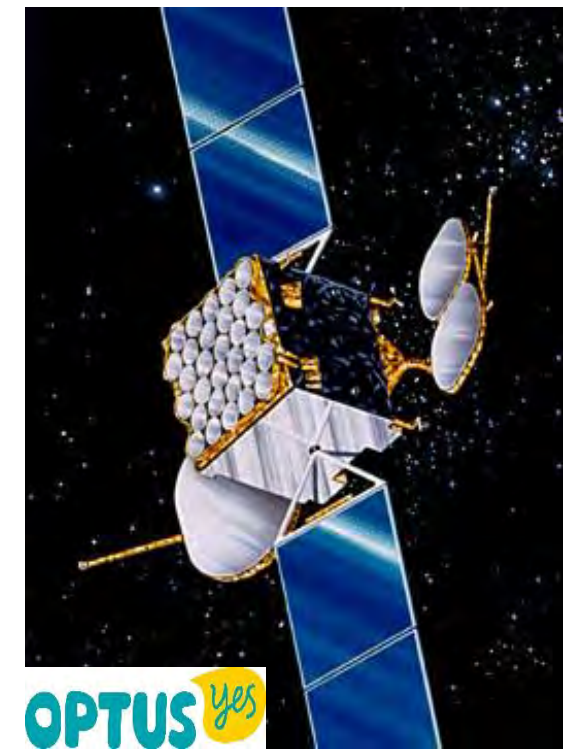
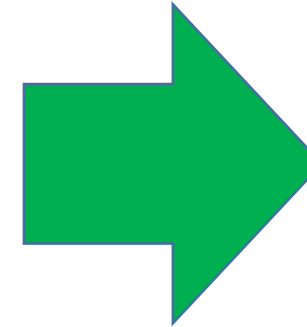
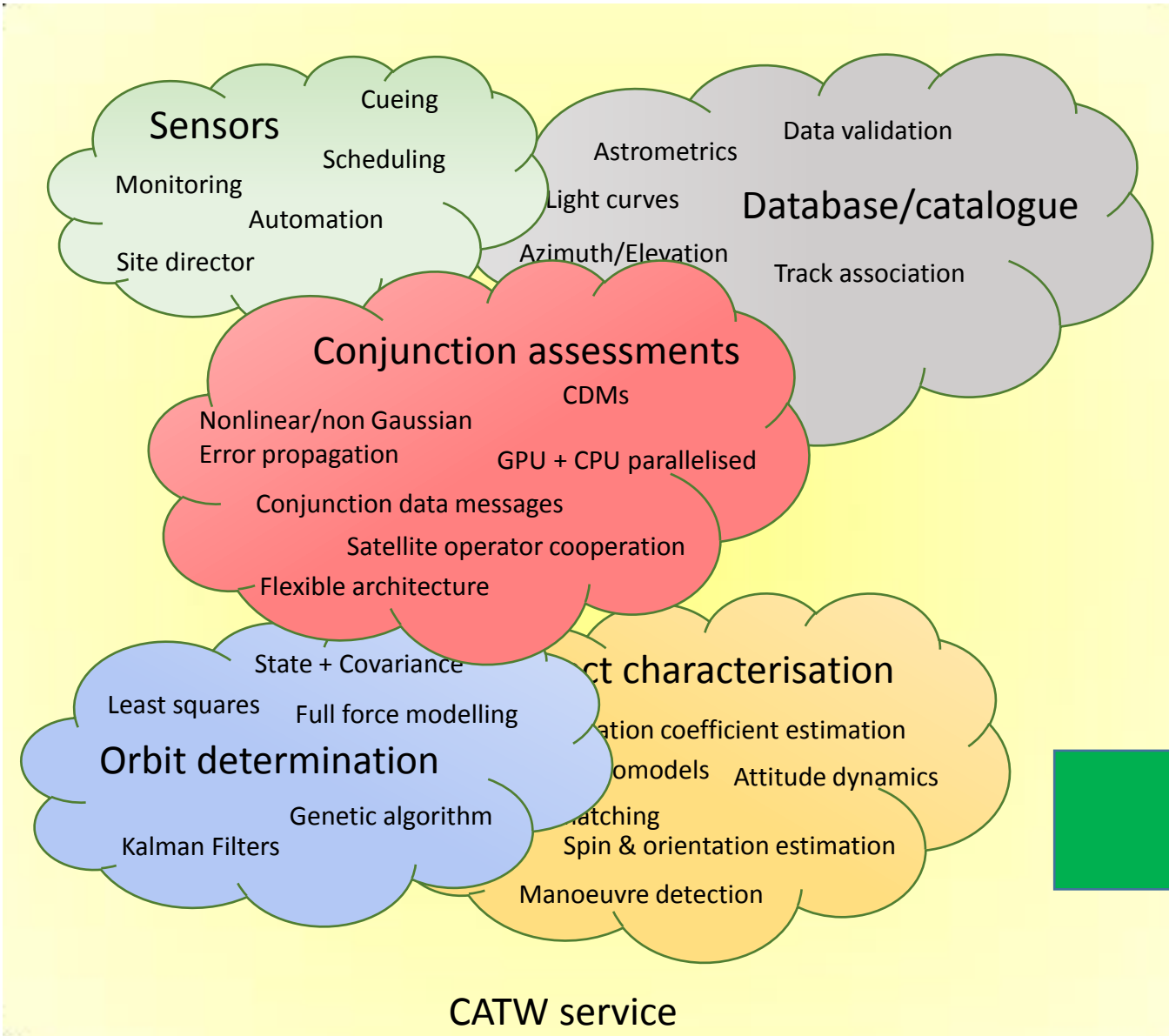

Where we are at...

Start Date	End Date	01/05	02/05	03/05	04/05	05/05	06/05	07/05	08/05	09/05	10/05	11/05
IS (AUISA)	16908											
SMOS 1989 (ETALON 1)	19751											
SMOS 2024 (ETALON 2)	20026			1	2							
GEOS 1				3	1	2					3	
GEOS 2			1		3	1	3					1
ARLETTE	076			1	1	1						
TELSAT 2-F1	06314					1						
ORAD AGENA D DEB	04161			1	1							
IRAN 1	09503			2	1	1						
-12 R/B(2)	13630			1	1	1						

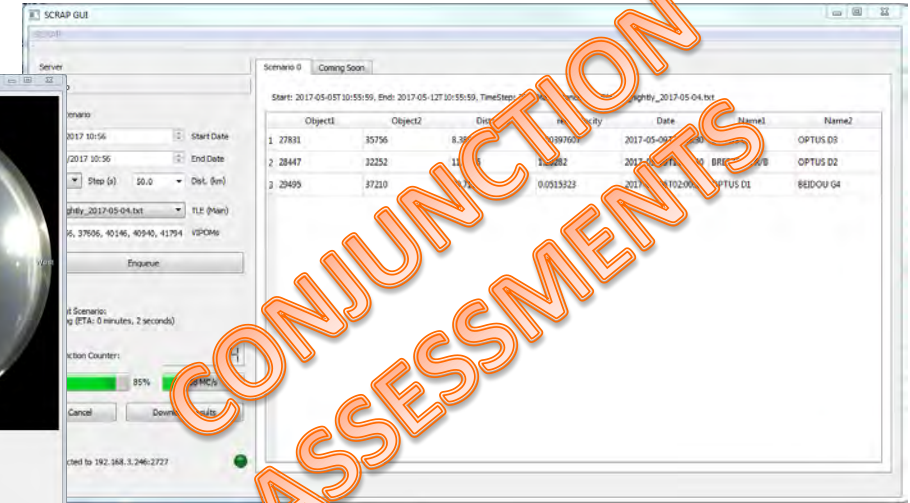
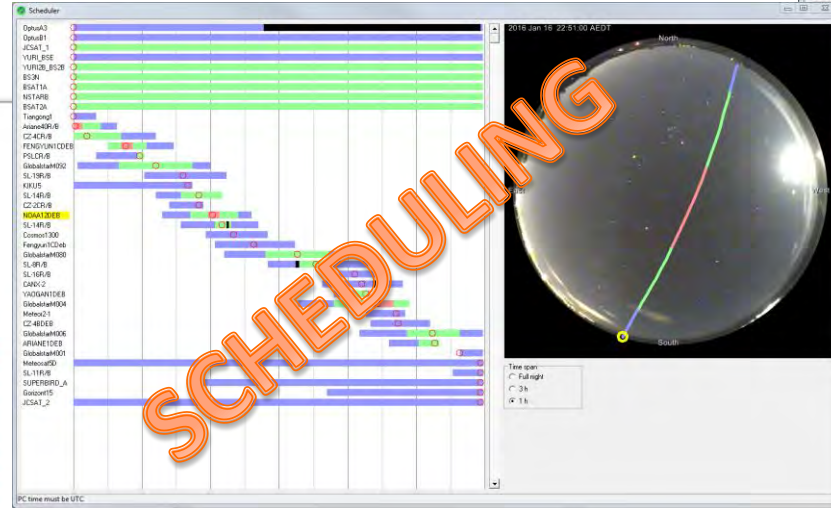

CATALOGUE

SCHEDULING

CONJUNCTION ASSESSMENTS

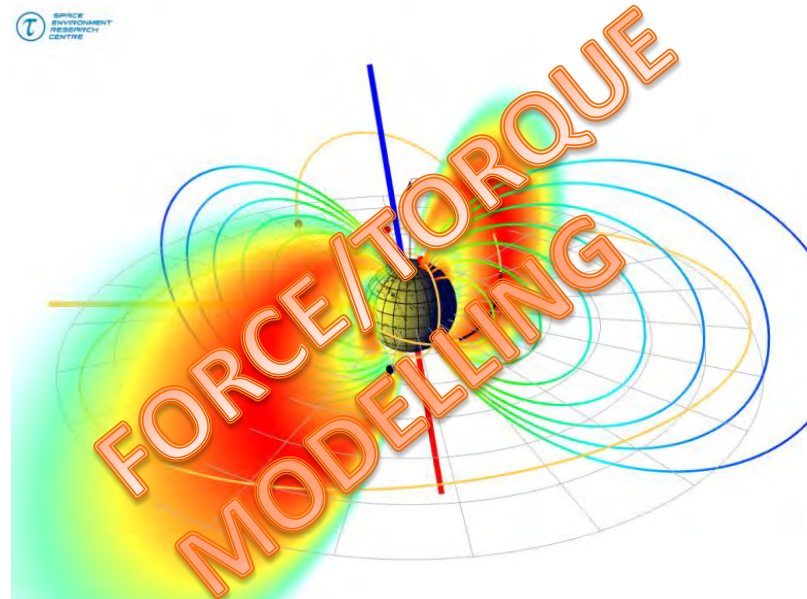
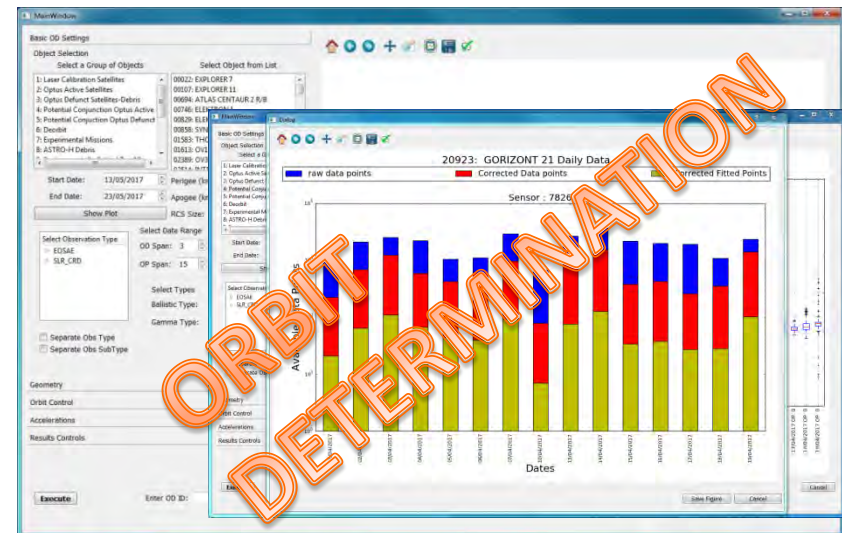

ORBIT DETERMINATION

FORCE/TORQUE MODELLING

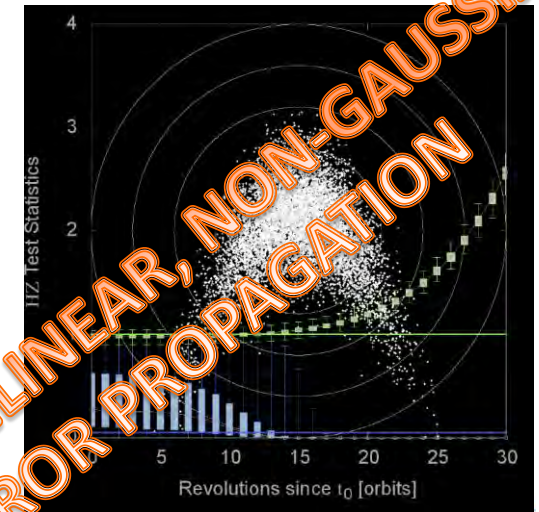

NONLINEAR, NON-GAUSSIAN ERROR PROPAGATION



## Post processing laser observations

- Active laser ranging produces azimuth, elevation and range measurements;
- Their rates of change are found using the post-processing method which fits the data.
- These observations can be then transformed into state vector form.

$$\begin{array}{|c|} \hline (\beta, \dot{\beta}, el, \dot{el}, \rho, \dot{\rho}) \\ \hline \end{array} \longrightarrow \begin{array}{|c|} \hline \mathbf{r}_{ECEF} = \mathbf{r}_{site,ECEF} + \boldsymbol{\rho}_{ECEF} \\ \mathbf{v}_{ECEF} = \dot{\boldsymbol{\rho}}_{ECEF} \\ \hline \end{array}$$

- Lageos 1 was chosen as the test case.
- 7 passes over a 10 day span.
- Generated  $\mathbf{r}$ ,  $\mathbf{v}$  directly from the observations.
- Residuals are determined using accurate ILRS states.

# Lageos 1 observation residuals – Euclidean distance

Position

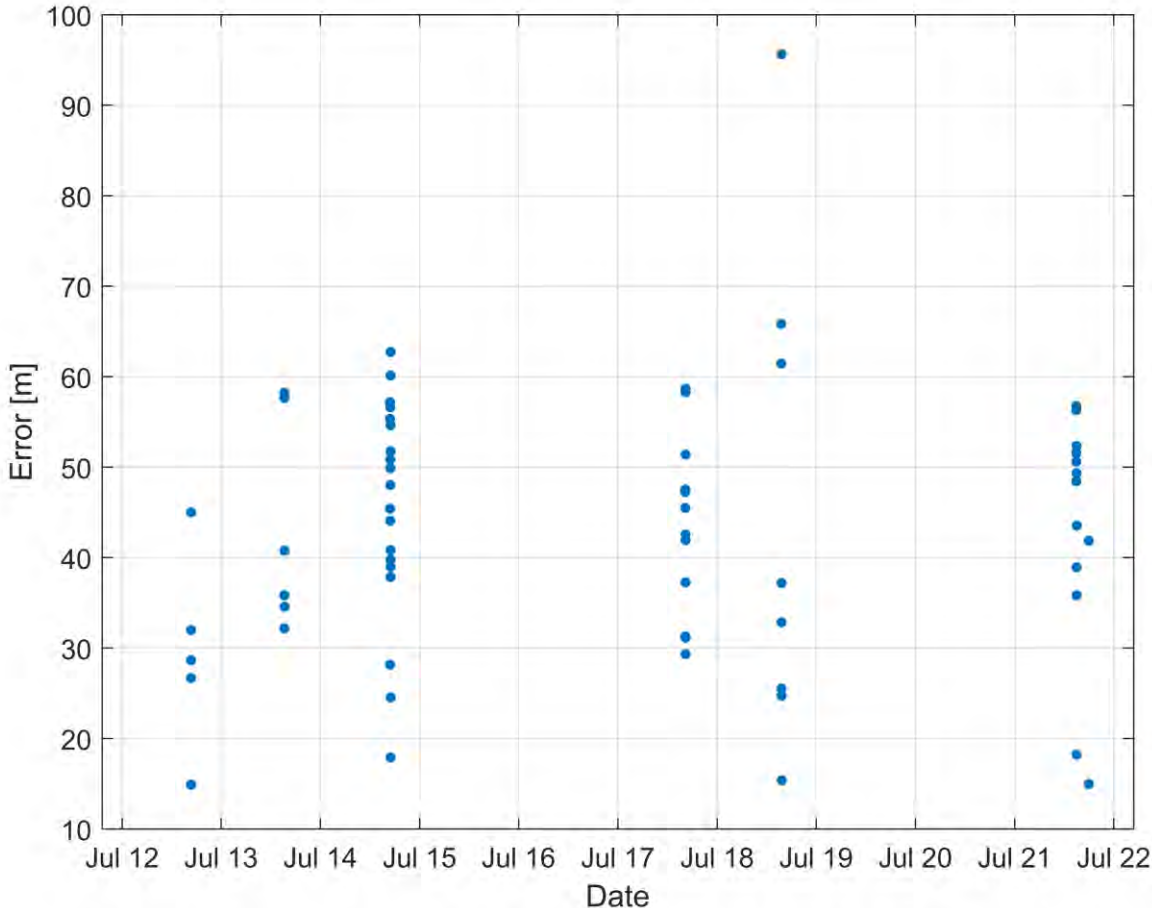

Velocity

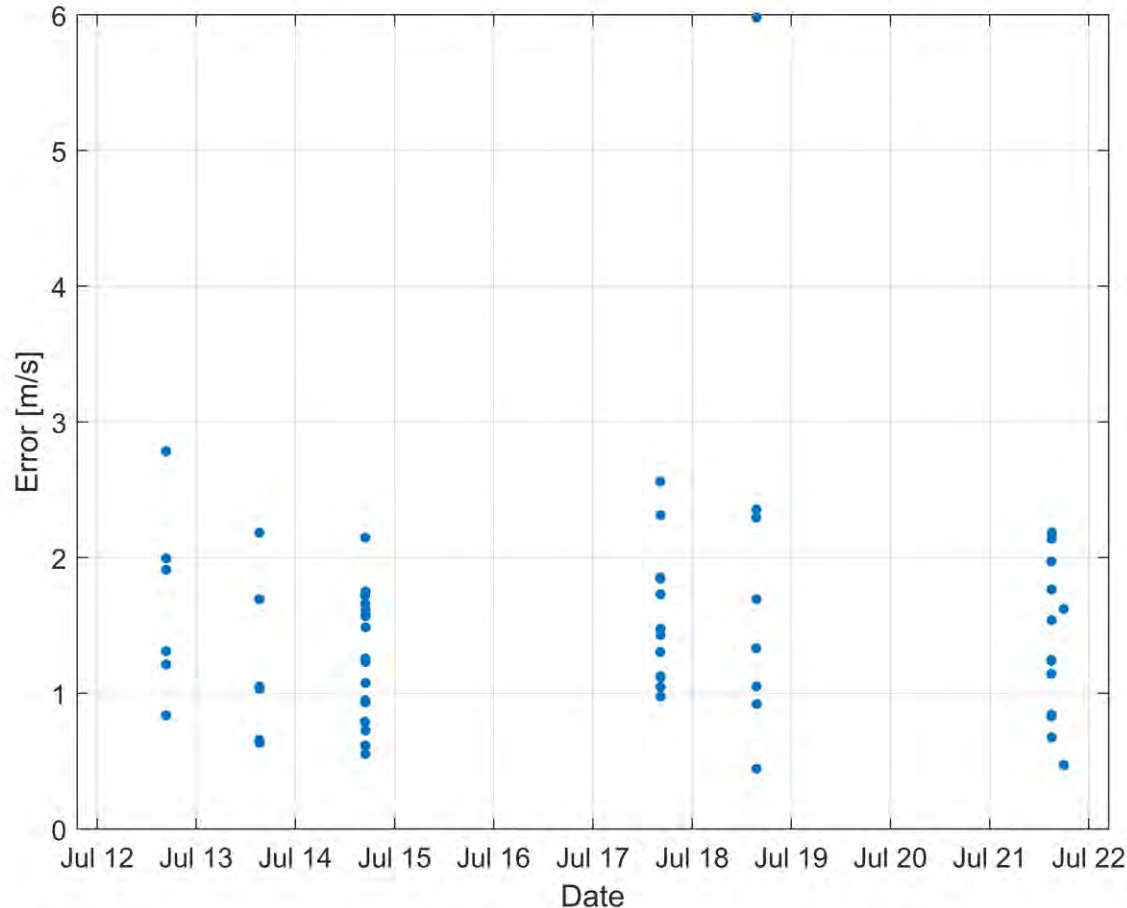

# Questions?

## James Bennett

Space Environment Research Centre,

EOS Space Systems

Email: [jbennett@eospace.com](mailto:jbennett@eospace.com)





[serc.org.au](http://serc.org.au)

[info@serc.org.au](mailto:info@serc.org.au)

 [facebook.com/serc.aus](https://facebook.com/serc.aus)

 [@serc\\_au](https://twitter.com/serc_au)



Australian Government  
Department of Industry and Science

**Business**  
Cooperative Research  
Centres Programme



## SAT TRACER - AN ALL AROUND SLR TOOL

SLR Station Graz

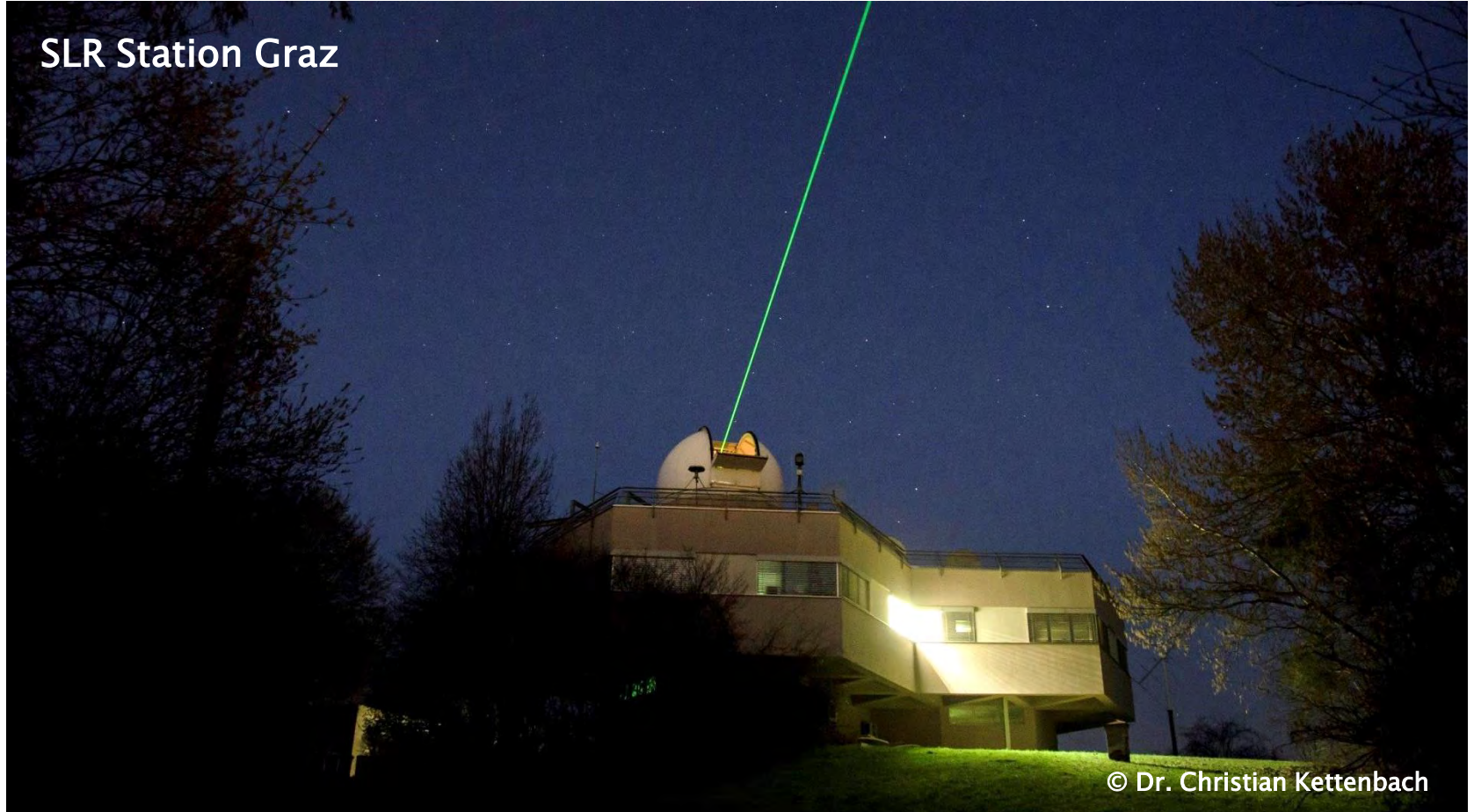

© Dr. Christian Kettenbach

Michael Steindorfer, Georg Kirchner, Franz Koidl, Peiyuan Wang  
Space Research Institute, Austrian Academy of Sciences

# SAT TRACER

Visual software tool to provide SLR related information on satellites

- Two satellite displays: Radar / World Map

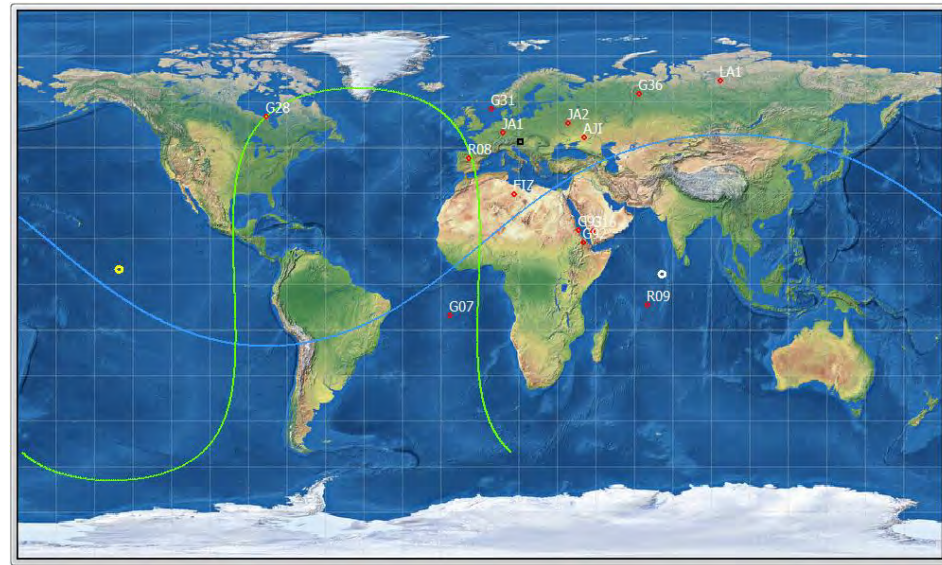
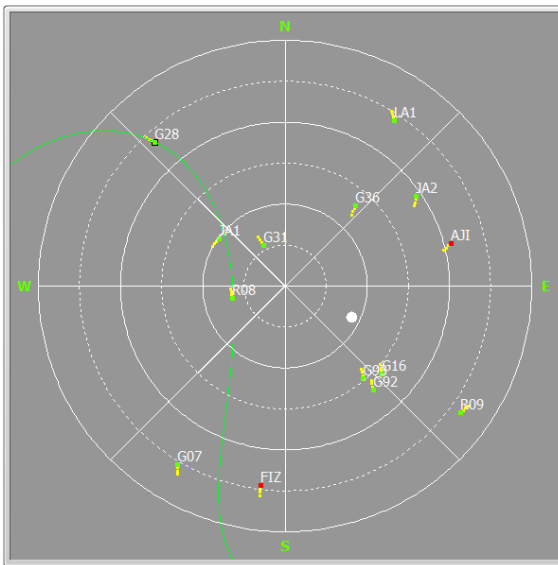

- SGP4 propagation -> position of any satellite at any time
- Download / Filter TLEs from Space-track.org / Load custom TLE file
- Display selectable for every SLR station (geographical coordinates)
- Can be run as EXE by installing using Labview runtime engine

## KEY FEATURES

- Click displays or list to select satellite
- Filter satellites based on revolution period (or other TLE criteria)
- Display optical satellite visibility (in earth shadow or sunlit)
- Display selected satellite path on Radar / World Map
- Movement of satellite relative to observer (% Up/Down, % Left/Right)
- Show visibility area of satellite on world map
- Show great circle of terminator phase line on world map
- Different Map Projections selectable
- Moon / Sun Position
  
- Highly customizable / software continuously under development

# FULL APPLICATION

World Map / Radar Settings Data

TLE path: D:\Daten\Simulationen\Labview\SGP4\TLE\TLE\_satdef  
 Station selection: 7839 Graz, Austria GRZL  
 Map Style: None

Satellite: AD1 Angular Dir: left +/- days: 0  
 Azimuth [\*]: 86,1853 Vertical Dir: down +/- hours: 5  
 Elevation [\*]: -30,7865 % Anuglar: NaN +/- min: -6  
 Range [km]: 7900,18 Sat\_sunlit:  +/- sec: 0

Night at Station:  TLE update [h]: 28,8  
 Sun El / Night [\*]: 0 Display % pass: 130  
 Radar angle [\*]: 0 Filter [rev/day]: 0  
 Sat elevation min [\*]: 10 Display path:

Map: Full/Station  get new TLEs space-track.org  
 label NORAD/3LE   
 Terminator circle   
 Visibility Circle

UTC: 20:05:47.944 08.09.2017  
 STOP Program

Satellites

- CG2
- CI2
- CI5
- ETS
- G03
- G16
- G27
- G31
- G32
- G35
- G36
- G64
- G71
- G92
- G93
- I1B
- I1F
- L08
- L12

# DIFFERENT STATIONS

- Full ILRS station list Monument Peak / Herstmonceux / Yaragadee / Riga

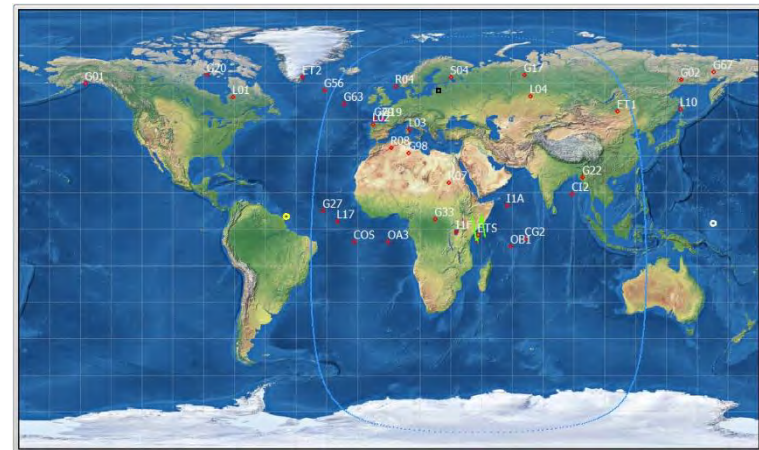
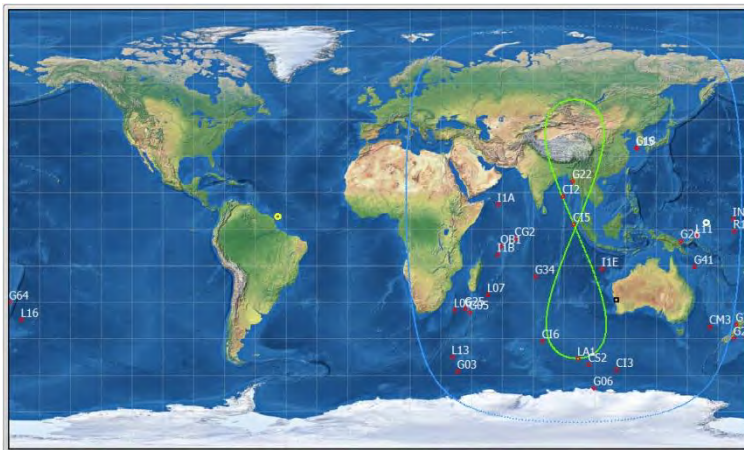

# FULL / STATION BASED VISIBILITY

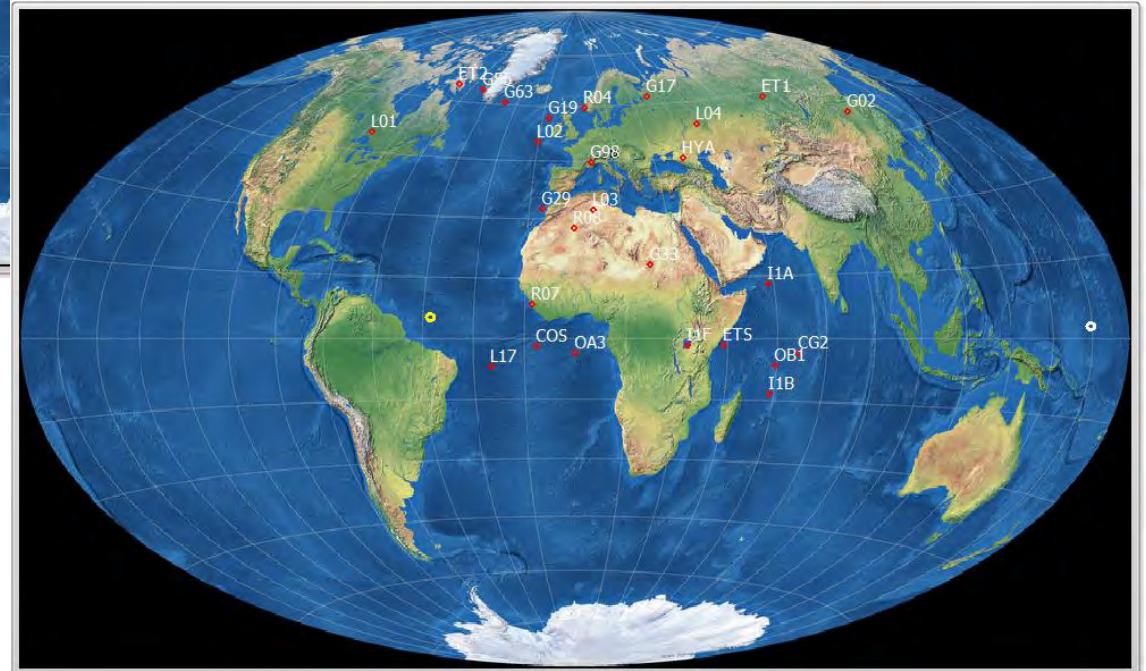
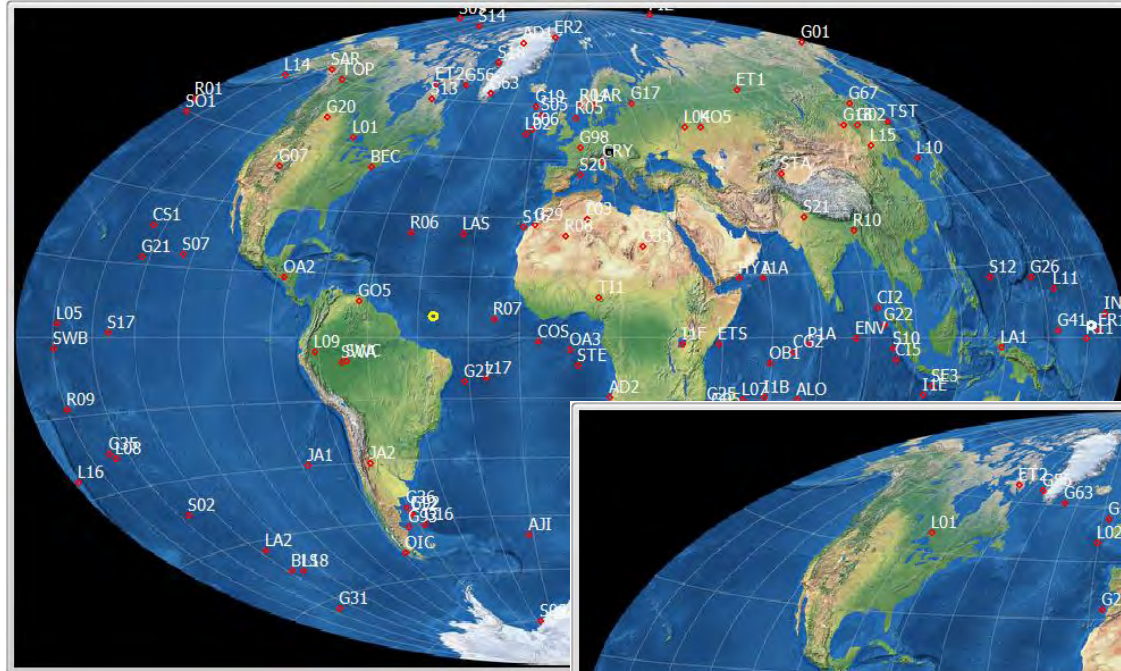

# SATELLITE PATHS / VISIBILITY CIRCLES

- Glonass (28917) / Envisat (27386) / ETS (29656) / I1B (39635)

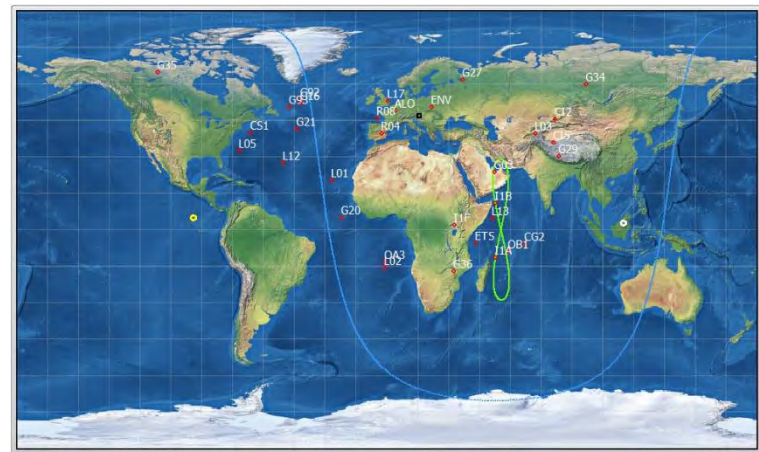
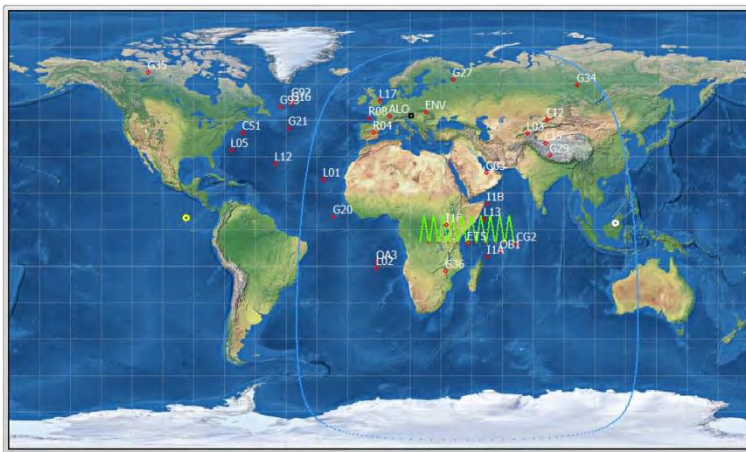

# FILTERING (REVOLUTION / DAY)





# ONE PASS / MULTIPLE PASSES

ETS (29656)

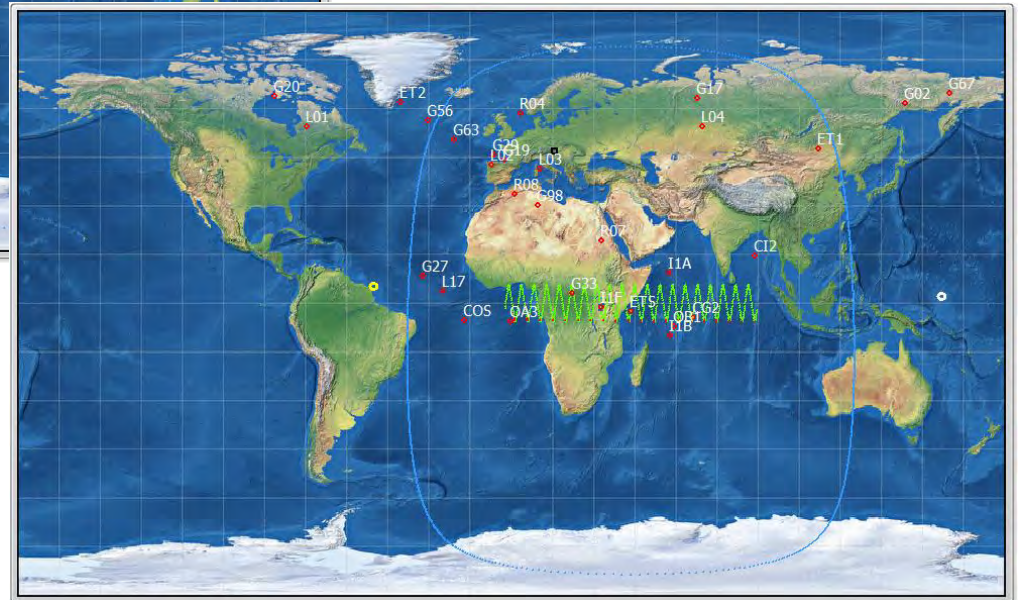
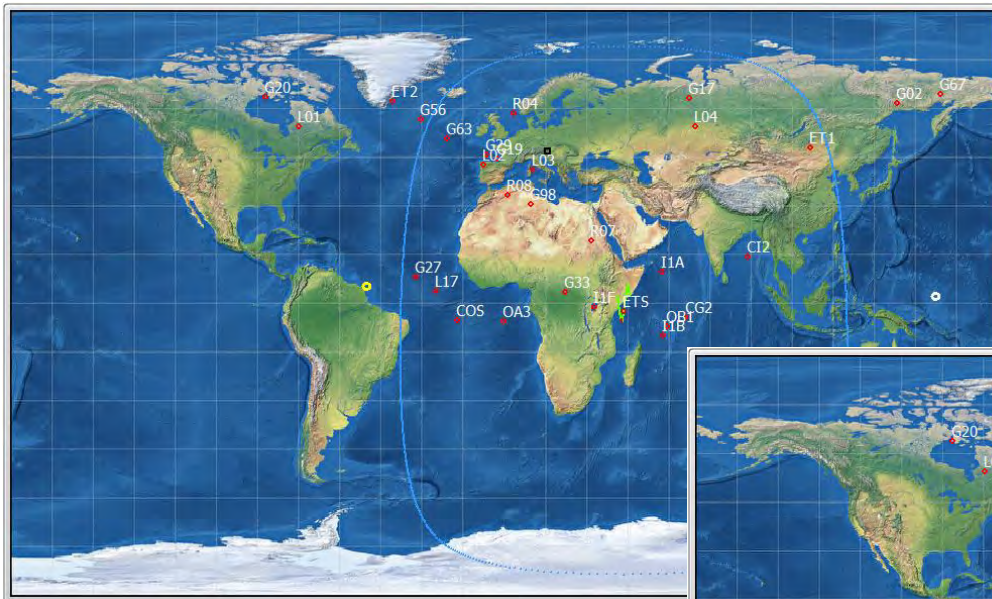

# SAT VISIBILITY: SUNLIT / IN SHADOW

SE3 (41335), R08 (40347)

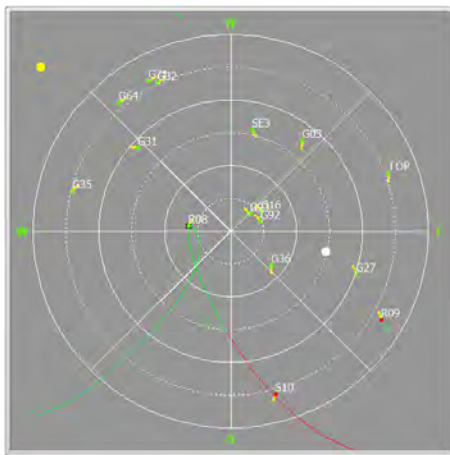
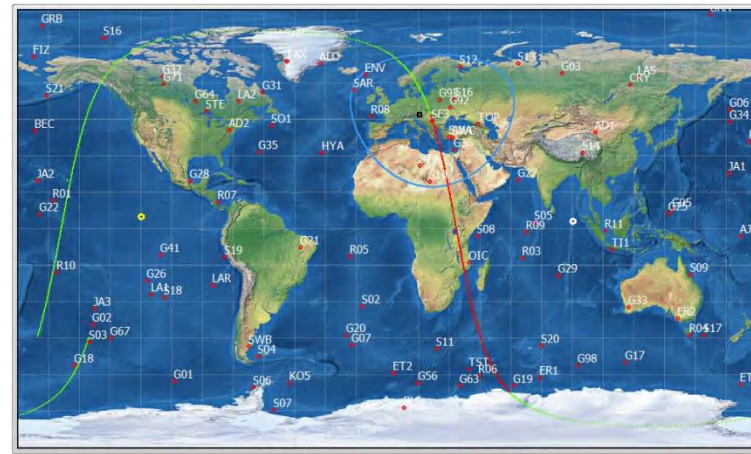
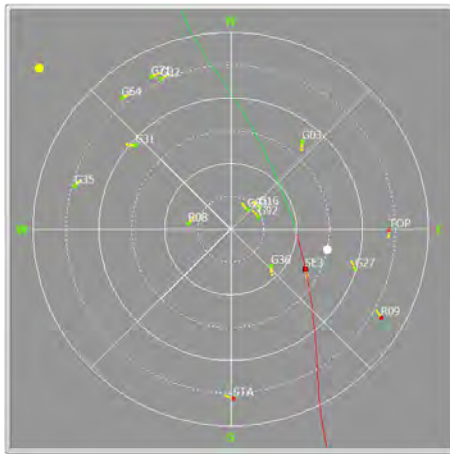

# TERMINATOR PHASE

- Great circles where sun has Elevation of:  $0^\circ$  /  $-6^\circ$  /  $-12^\circ$  /  $-18^\circ$

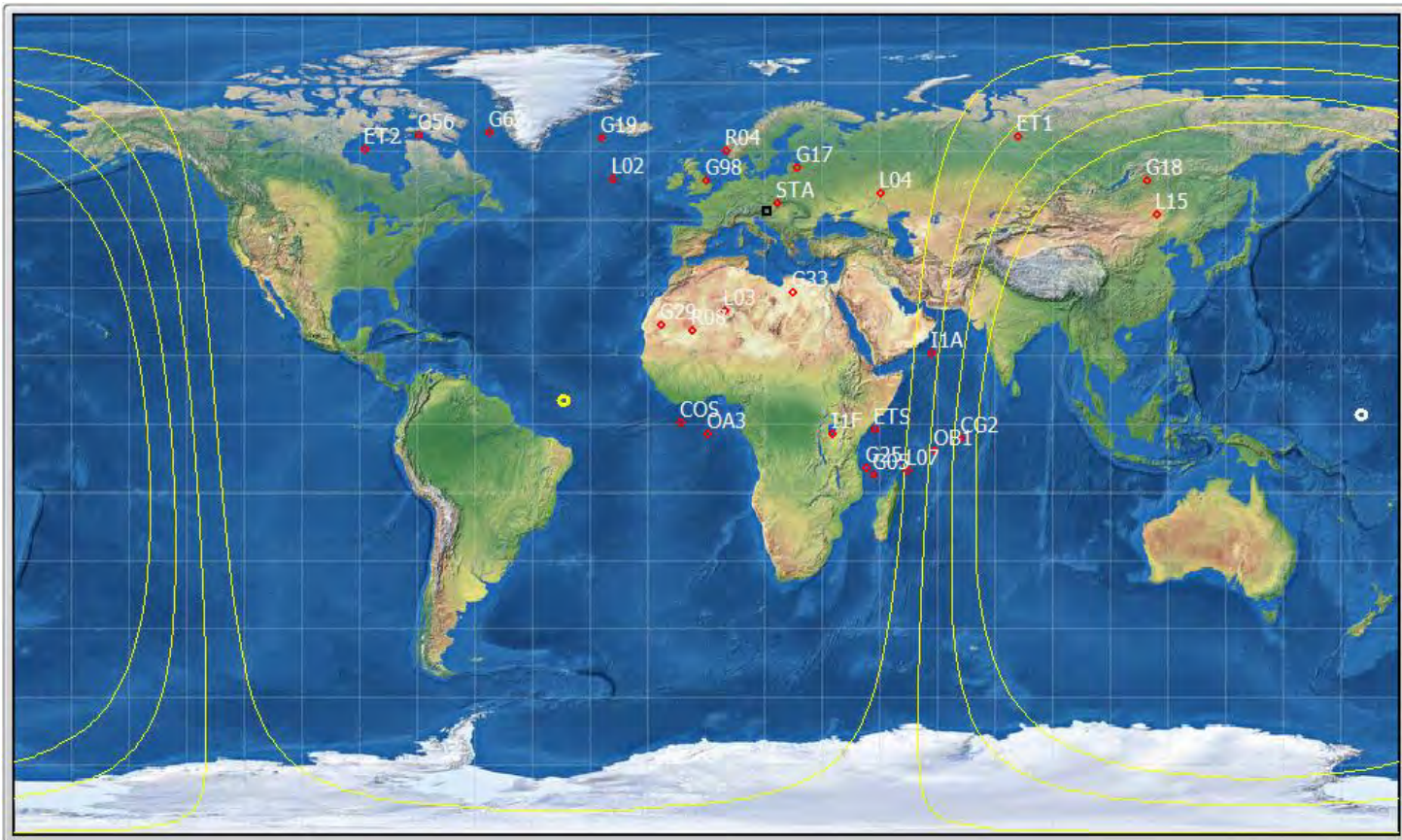

# WORLD MAP PROJECTIONS

- Equirectangular / Winkel Tripel / Gall Peters / Hammer

